

NOTE:
AXLE & CRANKPIN SEAT TOLERANCE +0.0/- 0.25

SECTION A-A
SCALE 1:5

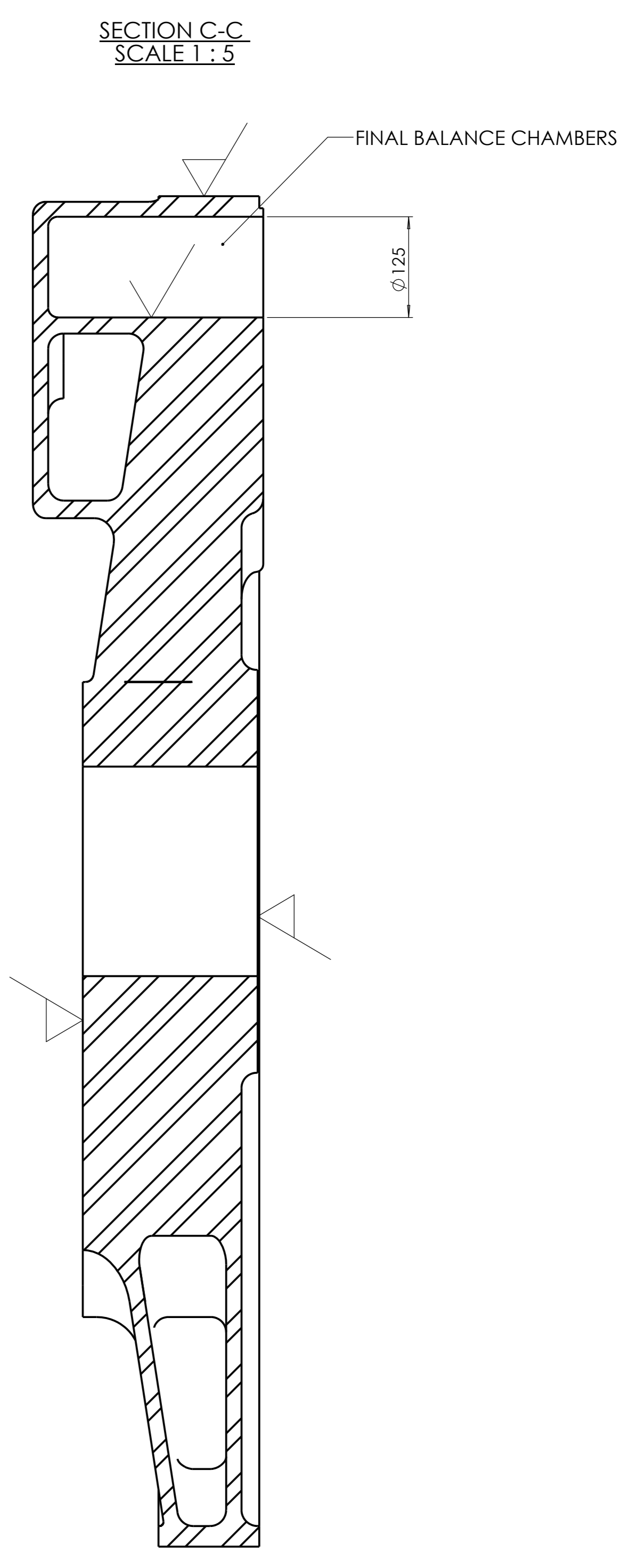
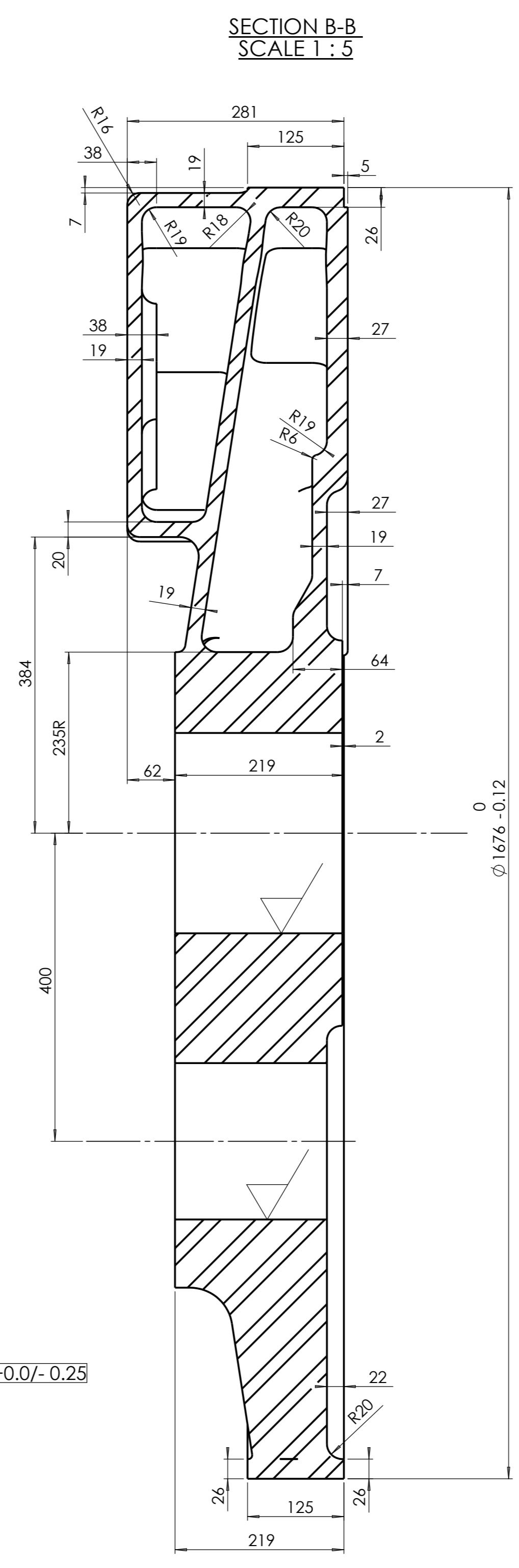
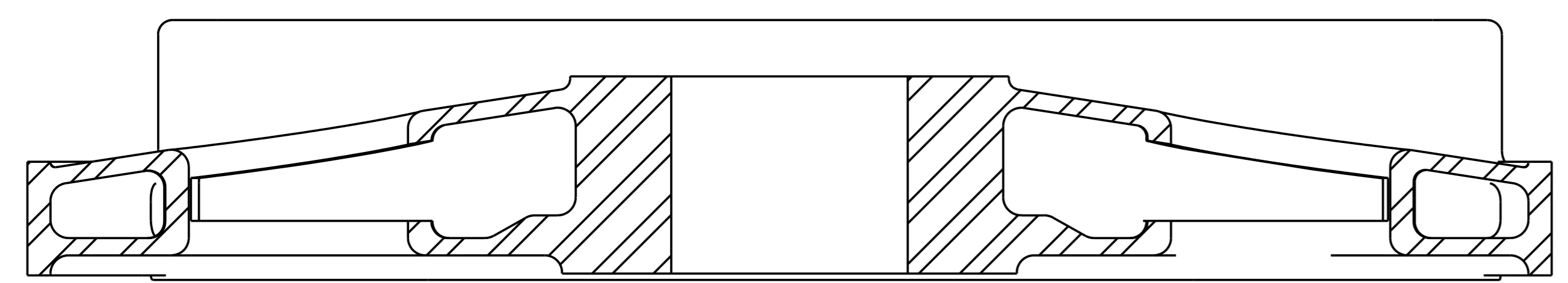

MACHINED COMPONENTS

- TOLERANCES UNLESS OTHERWISE STATED :
 LINEAR DIMENSIONS: 100 AND UNDER: ±0.25mm
 LINEAR DIMENSIONS: OVER 100 AND UNDER 1000: ±0.5mm
 LINEAR DIMENSIONS: OVER 1000: ±1.0mm
 ANGULAR DIMENSIONS: ±1°
 HOLE POSITIONS: ±0.1mm
- REMOVE ALL BURRS AND SHARP EDGES.
- SURFACE TEXTURE INDICATED IN ACCORDANCE WITH BS EN ISO 1302:2002
 SURFACE TEXTURE: BOSS SYMBOLS: MACHINING NOT ALLOWED
 UNMACHINED: MACHINED: MACHINING NOT ALLOWED
- MACHINE SURFACES: UNLESS OTHERWISE STATED
- ALL METRIC THREADS TO BS 3643 PT 2:1981 (6H / 6g FIT).
 ALL METRIC LENGTHS AND INTERNAL DEPTHS TO BE FULL THREAD UNLESS OTHERWISE STATED.

REV. NO.	REVISION	DATE
1	DESIGN AND BREAK SHARP EDGES	30/11/06

REV. NO.	REVISION	DATE
1	DESIGN AND BREAK SHARP EDGES	30/11/06

DO NOT SCALE DRAWING

MATERIAL: ALLOY STEEL
SPEC. T.B.A.

FINISH:

NAME	DATE
DRAWN: RC	30/11/06
CHK'D:	
APP'VD:	
MFG:	
Q.A:	

TITLE: MAIN DRIVING WHEEL CASTING

DRG NO. SHEET 1 OF 2

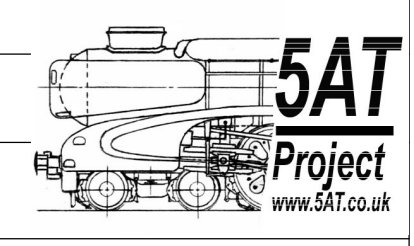

**VARIOUS SECTION CUTS AND OUTSIDE FRONT & BACK VIEWS
TO ILLUSTRATE & CLARIFY CASTING DETAILS**

VIEW INSIDE REAR FACE OF WHEEL

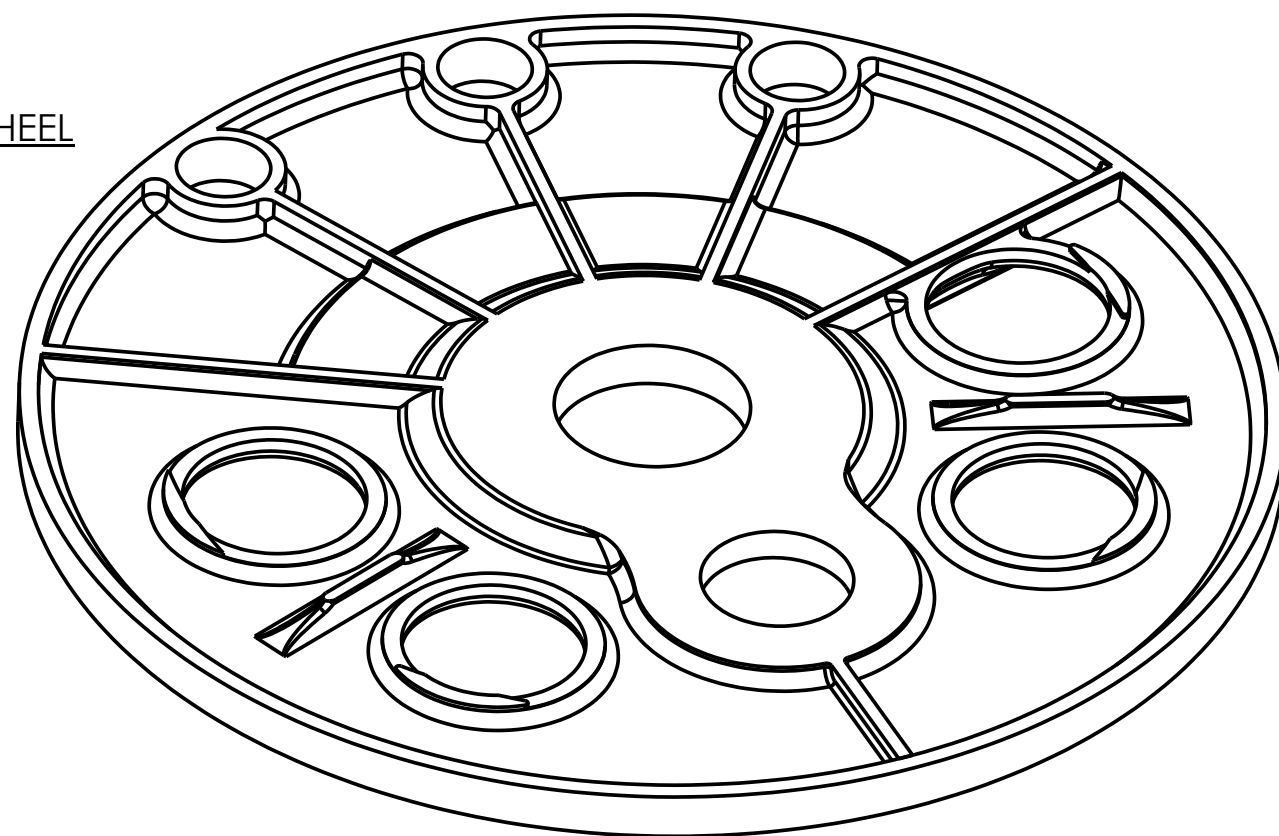

VIEW INSIDE FRONT FACE OF WHEEL

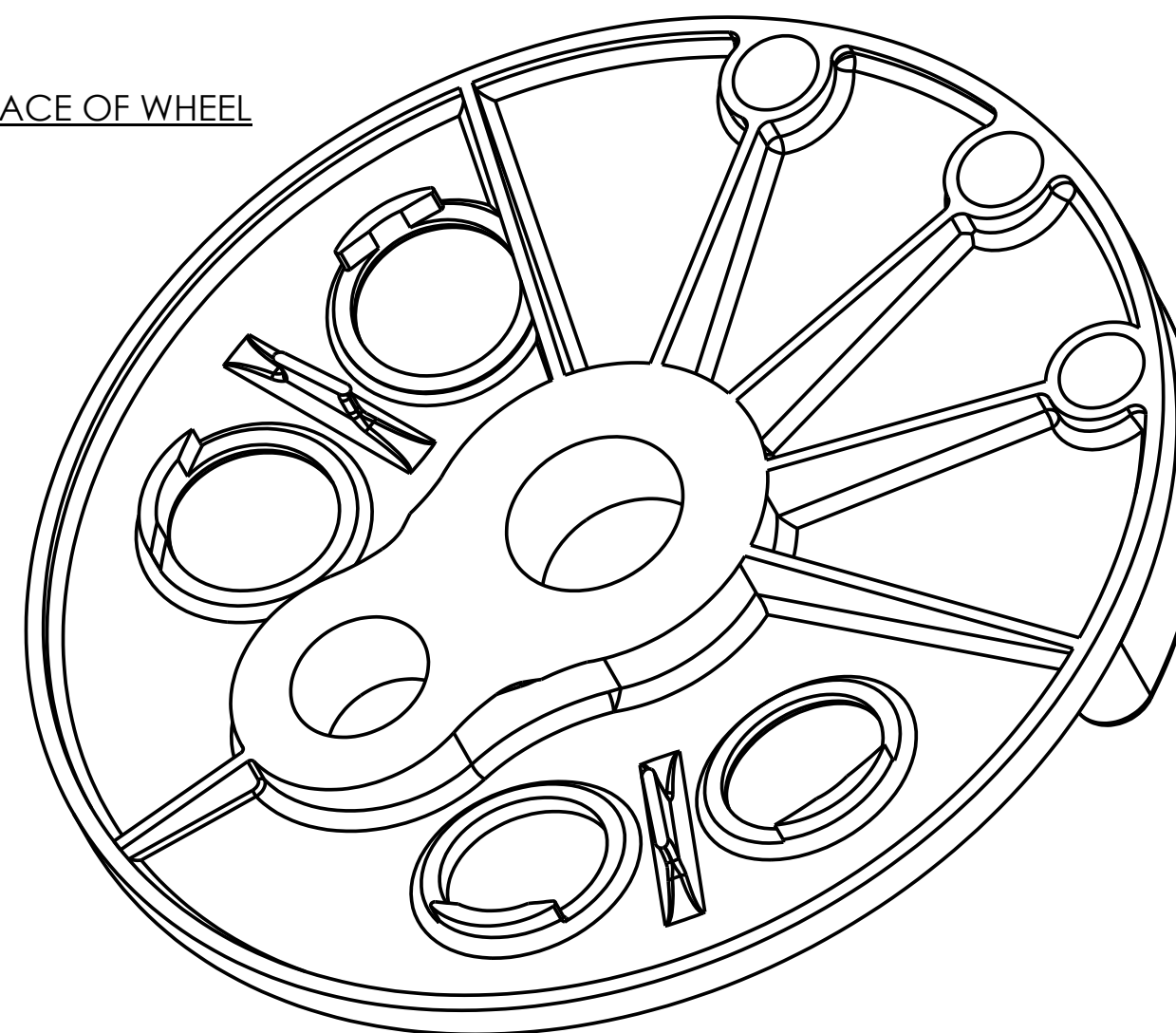

REAR VIEW OF FINISHED CASTING

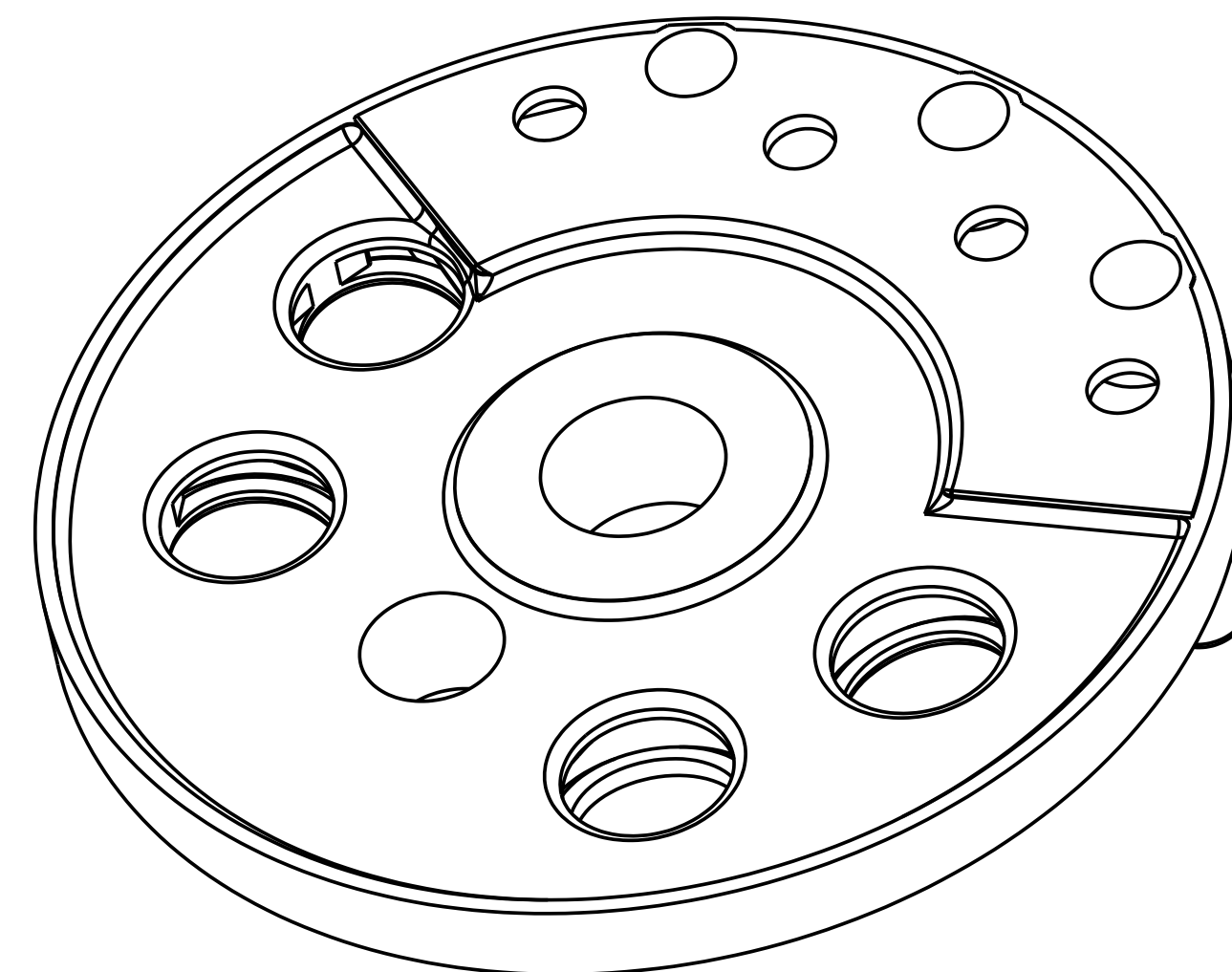

VIEW WITH FRONT FACE OF C/WEIGHT BOX REMOVED

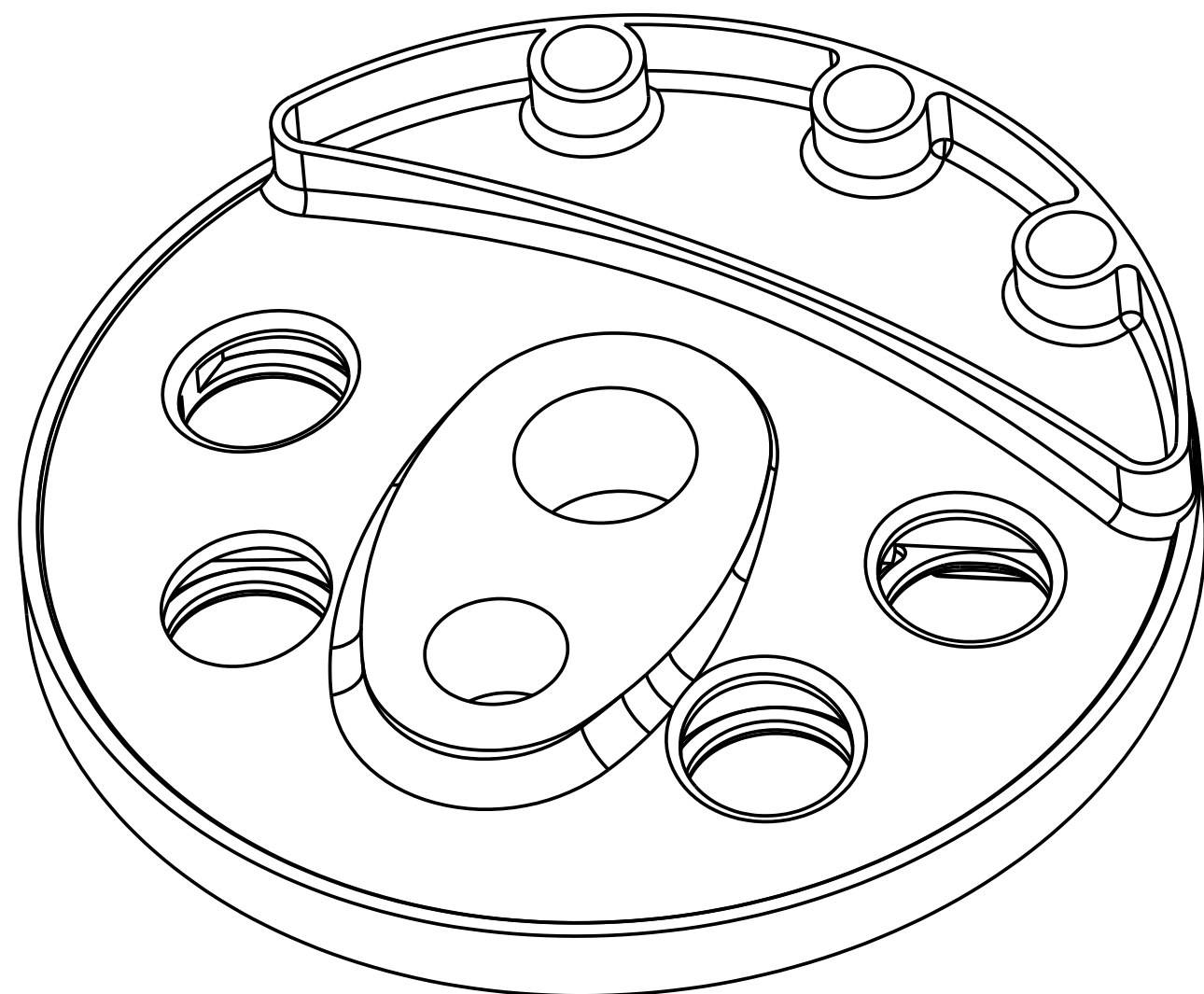

FRONT VIEW OF FINISHED CASTING

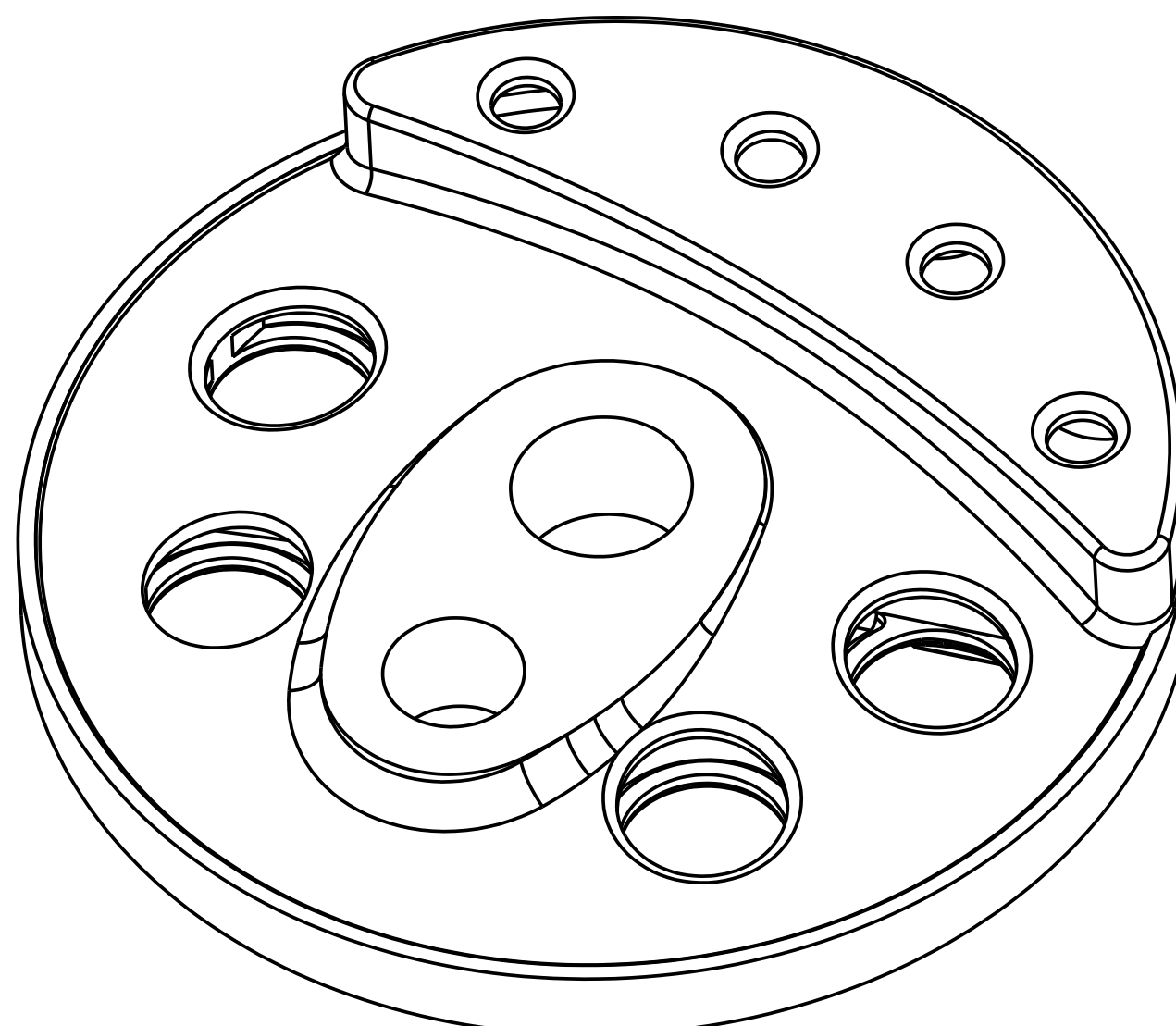

MACHINED COMPONENTS	
1. TOLERANCES UNLESS OTHERWISE STATED :	
LINEAR DIMENSIONS 100 AND UNDER	±0.25mm
LINEAR DIMENSIONS OVER 100 AND UNDER 1000	±0.5mm
LINEAR DIMENSIONS OVER 1000	±1.0mm
ANGULAR DIMENSIONS	±7-15'
HOLE POSITIONS	±0.5
2. REMOVE ALL BURRS AND SHARP EDGES.	
3. SURFACE TEXTURE INDICATED IN ACCORDANCE WITH BS EN ISO 1302:2002	
SURFACE TEXTURE BASIC SYMBOLS	
UNMACHINED ✓ MACHINED ✓ MACHINING NOT ALLOWED ✓	
4. MACHINE SURFACES UNLESS OTHERWISE STATED	
5. ALL METRIC THREADS TO BS 3643 PT 2:1981 (6H / 6g FIT).	
ALL METRIC LENGTHS AND INTERNAL DEPTHS TO BE FULL THREAD UNLESS OTHERWISE STATED	

	NAME	DATE
DRAWN	RC	30/11/06
CHK'D		
APPVD		
MFG		
Q.A		

REV. NO.	REVISION	DATE
	DO NOT SCALE DRAWING	
MATERIAL: ALLOY STEEL SPEC. T.B.A.		
FINISH:		
TITLE: MAIN DRIVING WHEEL CASTING		
DRG NO.		SHEET 2 OF 2 A1

