

SECTION 'C-C'  
TYPICAL SPOKE SECTION

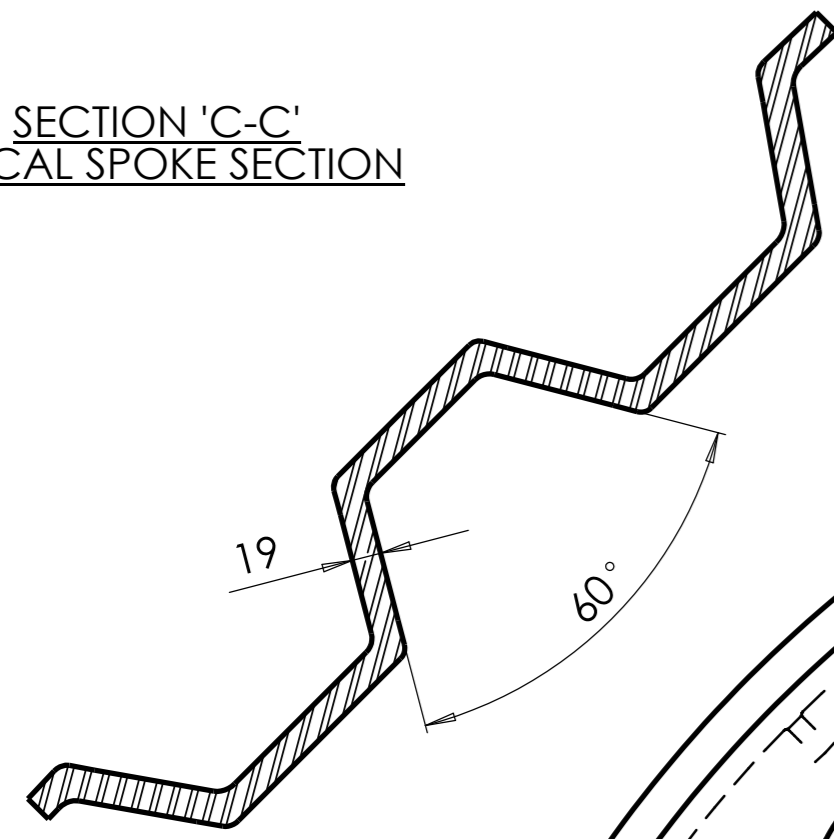

SECTION D-D  
SCALE 1:2

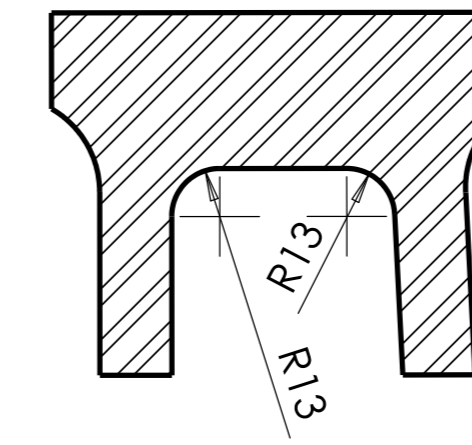

SECTION A-A  
SCALE 1:2

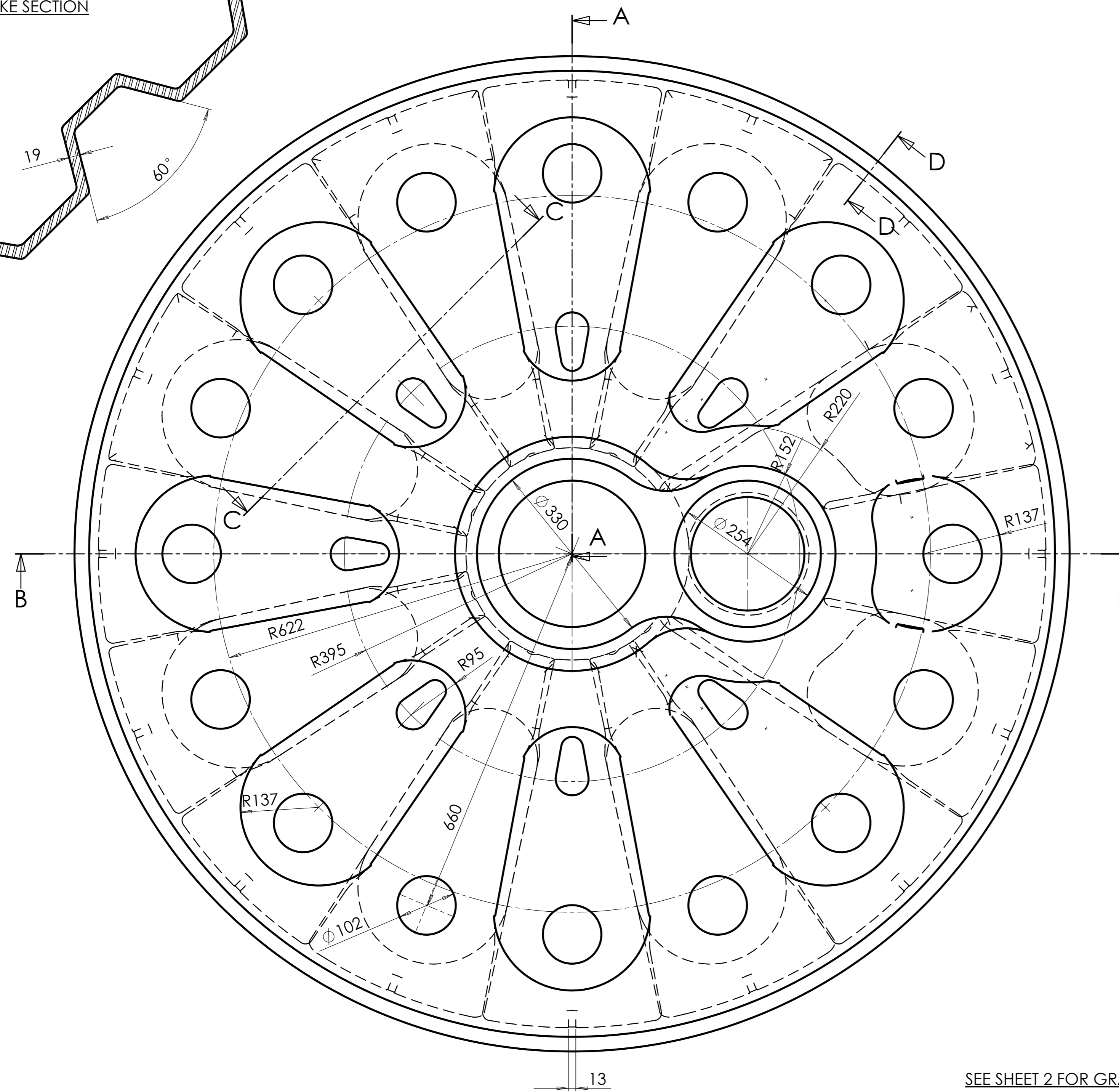
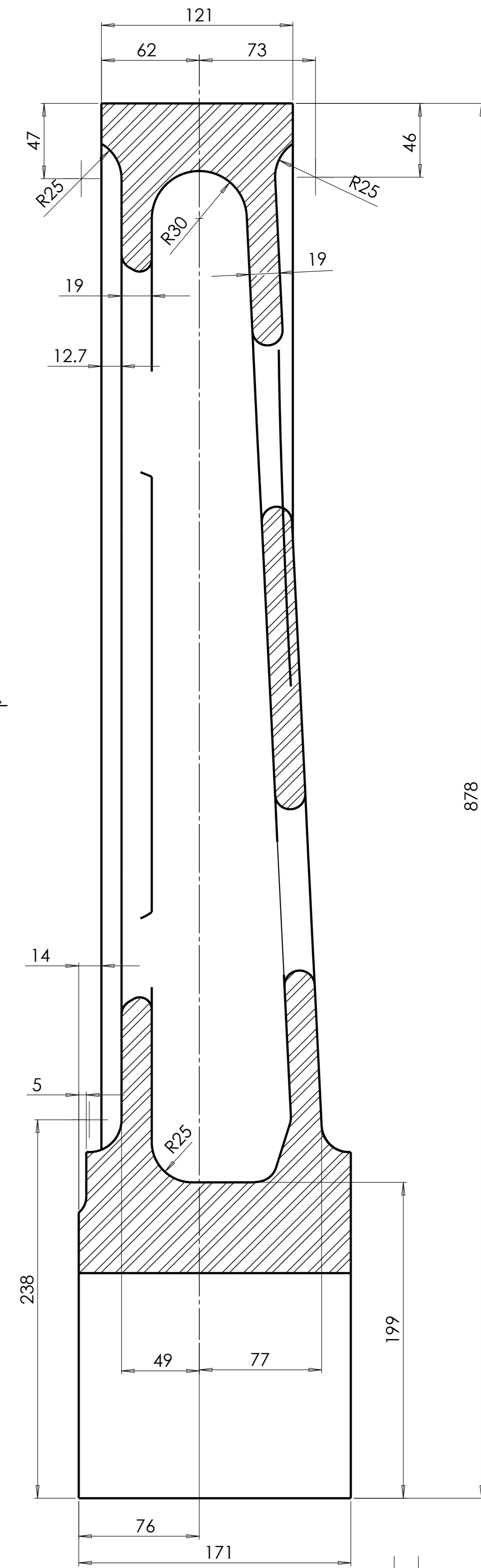

SEE SHEET 2 FOR GRAPHIC REPRESENTATIONS

SECTION B-B  
SCALE 1:5

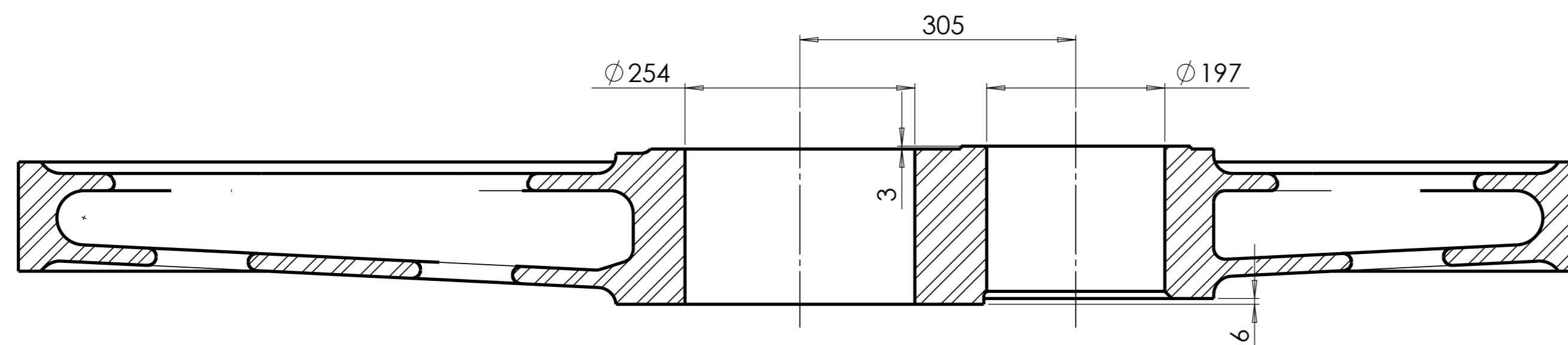

MACHINED COMPONENTS

- TOLERANCES UNLESS OTHERWISE STATED :  
 LINEAR DIMENSIONS: 100 AND UNDER: ±0.25mm  
 LINEAR DIMENSIONS: OVER 100 AND UNDER 1000: ±0.5mm  
 LINEAR DIMENSIONS: OVER 1000: ±1.0mm  
 ANGULAR DIMENSIONS: ±1°  
 HOLE POSITIONS: ±0.1mm
- REMOVE ALL BURRS AND SHARP EDGES.
- SURFACE TEXTURE INDICATED IN ACCORDANCE WITH BS EN ISO 1302:2002  
 SURFACE TEXTURE: BORE SYMBOLS: UNMACHINED ✓ MACHINED ✓ MACHINING NOT ALLOWED ✓  
 MACHINE SURFACES: ✓ UNLESS OTHERWISE STATED
- ALL METRIC THREADS TO BS 3643 PT 2:1981 (6H / 6g FIT).
- ALL METRIC LENGTHS AND INTERNAL DEPTHS TO BE FULL THREAD UNLESS OTHERWISE STATED.

NAME	DATE
DRAWN	RC
CHK'D	
APP'VD	
MFG	
Q.A	

REV. NO.	REVISION	DATE

DO NOT SCALE DRAWING

MATERIAL: CAST ALLOY STEEL

FINISH:

TITLE: BOXPOK WHEEL CENTRE

DRG NO.

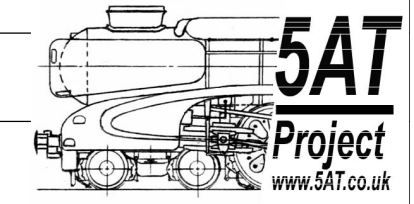

SHEET 1 OF 2

