

SEMINARICO INTERNACIONAL DE
DESARROLLO TECNOLOGICO FERROVIARIO FF.CC. NACIONALES DE
MEJICO

GUADALAJARA - MEJICO

MARZO 31 – ABRIL 1Y 2, 1987

THE CONTRIBUTION OF
A NEW STEAM-MOTIVE POWER
TO AN OIL-LESS WORLD

ING. LIVIO D. PORTA
TECHNICAL ADVISER
TO THE PRESIDENT
OF THE ARGENTINEAN RAILWAYS

PREFACE TO THE ENGLISH TRANSLATION

This is not necessarily a literal translation of the original paper presented at the Mexico seminar because: (a) it includes some reflections resulting from informal discussions therein, (b) it gives some additional data, and (c) minor errors have been corrected. The message to the Mexicans, who asked for the study, remains unchanged, namely: that there is a new advanced steam motive power technology which can be taken advantage of in a context of not using oil under extremely difficult financial conditions.

THE CONTRIBUTION OF NEW STEAM MOTIVE POWER TO AN OIL-LESS WORLD

SUMMARY

Oil is expensive, and the present fall in its price is no more than an oscillation superimposed to a rising trend caused by finite reserves. Any country, having oil or not, pays a high price for what is used in the internal market: if it has oil and uses it, it cannot export it at international prices far above production costs; if it has no oil, it must be imported at international prices.

Railway steam motive power, particularly that of advanced technology by the development work silently occurred during the last forty years, offers the possibility of using coal and wood. This can be carried out within a technological spectrum spanning from developments still at speculative levels with 27% thermal efficiencies, down to the partial application of the new principles to old existing locomotives whose efficiency can attain 13%.

In spite of figures as low as 13%, and even working with oil, the new steam technology is (at least locally) competitive with a diesel requiring a fuel three times more costly on a Btu basis. Then coal is used with a higher efficiency, the total costs are much lower. This of course requires an evaluation for each particular case.

The GPCS (Gas Producer Combustion System), in commercial use for more than thirty years, is a solution for old coal burning problems. In its present state of development, it is also a solution for those related to environment protection.

Perhaps the most important is that steam power can work on solar energy. A mechanized combustion using the whole of the forest biomass is now in course of development: *WE MUST SOW FUELWOOD!* In the case of Brazil, a fast growing species is the BRACATINGA (*Mimosa scabrella*, BENTH).

The progress carried out since 1950 consists of:

- (i) improvements in the theoretical thermodynamic cycle: higher steam pressures, very high steam temperatures, regenerative cycle including air and feedwater heating, etc.;
- (ii) a considerable improvement in the efficiency with which the real machine accommodates itself within the bounds of the theoretical heat engine: improvements in internal streamlining, elimination of various losses (steam leakage, cold starting losses, frictions, etc.);
- (iii) an increase in the power-to-weight ratio; high steam production; high piston speed, etc.;
- (iv) mechanical and ergonomic improvements, etc.

The STEVENSONIAN conception continues to be adhered to, with a reciprocating engine and firetube boiler.

An extensive bibliographical list is included.



Livio Dante PORTA

References.

- (1) PORTA, L.D.: " An Essay -- The Russian Approach to Friction and Wear Problems as Applied to PORTA Advanced Steam Locomotive Technology", (in preparation).
- (2) STOFFELS, W.: "Lokomotivbau and Dampftechnik". BIRKHAUSER Verlag, Bassel u. Stuttgart, 1976.
- (3) CHAPELON, A.: "La Locomotive a Vapeur". BAILLIERES et Fil, Paris 1935.
- (4) PORTA, L.D.: "Steam Locomotive Development in Argentina - Its Contribution to the Future of Railway Technology in the Under Developed Countries". J. Inst. Locomotive Eng., Session 1969-70, Pt 2.
- (5) ZOELLY: "Turbine-Driven Locomotive". Mechanical Engineering 46, 11, 653-660 (1924).
- (6) NIFFENEGGER: " Die ZOELLY Dampfturbinen Lokomotive". ESCIHER-WYSS Mitteilungen 1, N° 2, 51-56; N° 3,95-100 y N° 5, 163-168 (1928).
- (7) PORTA, L.D.: "La traction a vapor en el contexto de la crisis energetica". XIII Pan American Railway Congress, Caracas, Venezuela, 1975 (There is also an English version).
- (8) HUTTE: "Manual del Ingeniero", tome II, translated from the 26th German edition, GUSTAVO GILL, Barcelona 1950.
- (9) Enciclopedia ESPASA, ESPASA CALPE, Barcelona: Word "Maquina".
- (10) PORTA, L.D.: "Steam Engine Cylinder Tribology", 1975 (*) (£).
- (11) "Gas Producer Combustion of Wood and Charcoal Fines ex-AHZ. Test on Locomotive N° 4674, FCGB." Carried out for the Argentine Association of Forest Industries. INTI-CIPUEC document, 1963.
- (12) PORTA, L.D.: "Steam Locomotive Boiler Feedwater Treatment". (1975) (*) (£).
- (13) PORTA, L.D.: "Calculo de la disociacion del Na₂CO₃ en calderas: correccion al modelo de P.T. DEE". Documento INTI, 1979.
- (14) PORTA, L.D.: "For the Record: Some Ideas on Advanced Steam Locomotive Tribology". ACE Document, 1985 (E).
- (15) PORTA, L.D.: " Recuperation y modernizacion de tree locomoras de vapor alimentadas con lena para el Paraguay. Algunos aspectos de la operation. Costos y rentabilidades". Documento interno de la Presidencia de Ferrocarriles Argentinos, 2-3-87.
- (16) PORTA, L.D. and WARDALE, D.: " Third Generation Steam: Facing the Energy Crisis". Paper submitted to the XIV Panamerican Railway Congress, Lima, Peru, 1978 (£).
- (17) Pan American. Railway Congress Association: "Mexico Declaration", Mexico 1981.
- (19) US Department of Energy. Office of Fossil Energy. Morgantown Energy Technology Center. Morgantown, West Virginia: "Assessment of Coal-Fuelled Locomotives" (1986).
- (20) South African Transport Services: Mechanical Engineer Department. Chief Mechanical Engineer's Office. Pretoria - Ref. RLS 15/2/22. TEL: 2 810: "Prototype 26 Class Locomotive N° 3450. Performance and Efficiency Test Report", 30-12-1983. (Not a public document).

- (21) GIRDLESTONE, P.: paper on the application of the Gas Producer Combustion Aystem to LINDA, a locomotive of the Festiniog Railway, Wales, Great Britain.
- (22) PORTA, L.D.: " 250 km/h con vapor en Argentina, con carbon de Rio Turbio". Jornadas de CADEF, Santa Rosa de Caiarnuchita, Argentina, April 1971 (E).
- (23) PORTA, L.D.: "Adhesion in Advanced Steam Locomotive Engineering Facing the Oil Crisis", (1976) (£)(*).
- (24) Informes de la CRER, Comision Res. P: 221//86, Ferrocarriles Argentinos.
- (25) PORTA, L.D.: "Note on the Responsiveness to Quick Load Changes of a Certain Well Known Type of Boiler When Burning Wood". Study for KALHALL, Sweden, 1978.
- (26) BRIDGE, P.: "Tumbler Ridge Coal Keeps Moving". Railway Gazette International, Oct. 1986.

List of references not mentioned in the text:

- (27) PORTA L.D.: "Una locomotora para el futuro". Jornadas Ferroviarias de Tucuman, Tucuman, Argentina, 1964 (£).
- (28) PORTA, L.D.: "L.D. PORTA: His Advanced Steam Locomotive Technologies and Their Extension to other Thermomechanical Fields". 1986(*) (pound sign!!).
- (29) PORTA, L.D.: "Advanced Shunting Locomotives for the Argentinean Railways" (in Spanish). (pound sign!!).
- (30) PORTA, L.D.: "El Sistema de Combustion a la Gasogena". Conferencia Internacional para el Uso Eficiente del Combustible en la Industria, INTI, Buenos Aires, Argentina, 1966.
- (31) PORTA, L.D.: "An Essay on Sulfur Emission Control in Advanced Steam Locomotive Technology". 1985 (*) (£).

(£) Containing information subjected to patent rights.

(*) Not published, manuscript copy available.

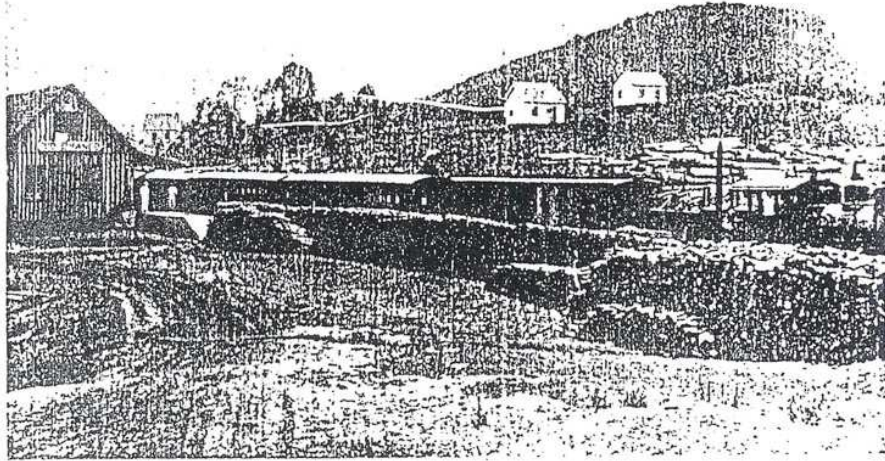

Railway station, Rio Branco do Sul, Paraná, Brazil. Before World War II, *Mimosa scabrella* was grown as fuel for railroads in parts of southern Brazil. (F.C. Hoelne)

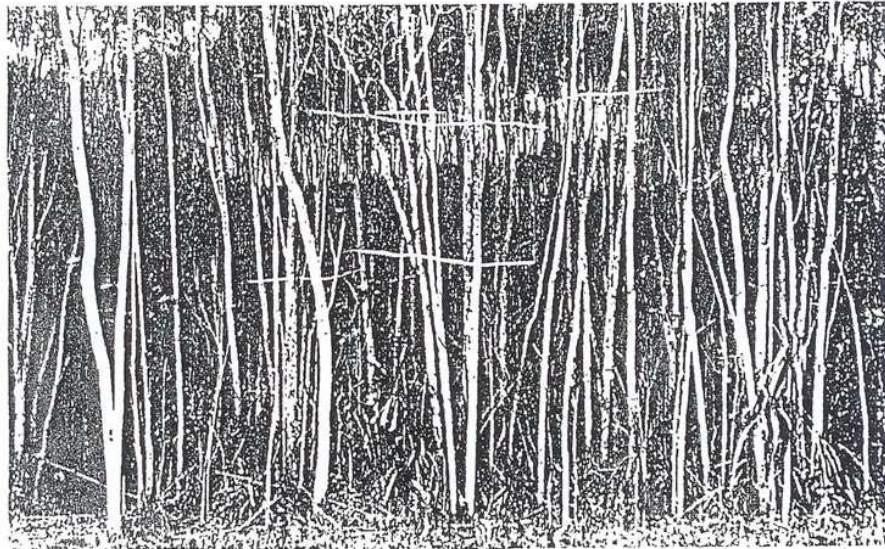

Curitiba, Paraná, Brazil. Natural regeneration of *Mimosa scabrella*, 3 years of age. (F.C. Hoelne)

Fig. 1: BRACATINGA, a fast growing tree for firewood plantations.

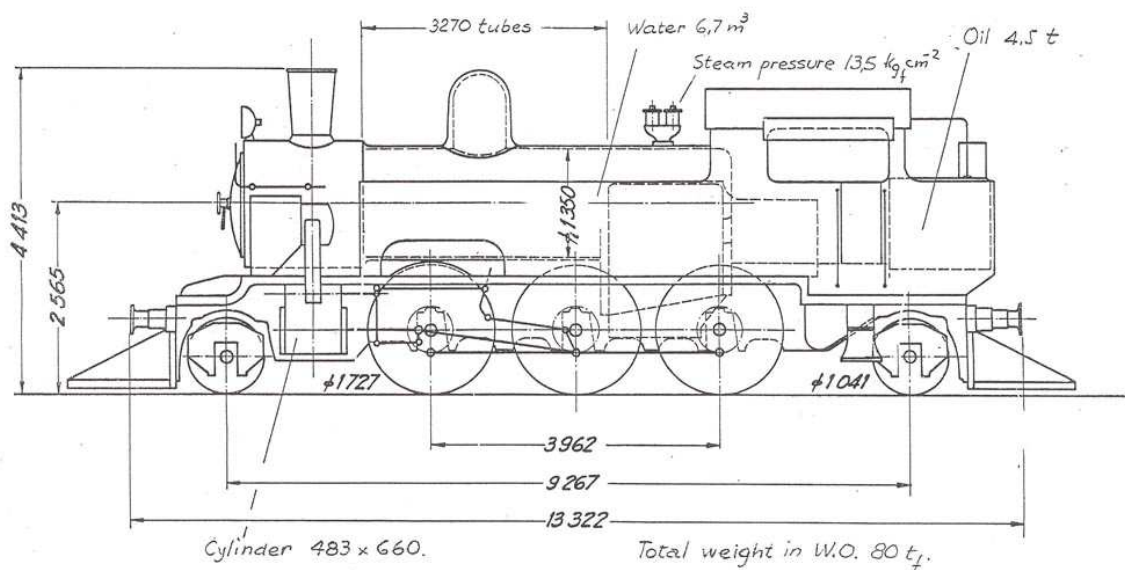
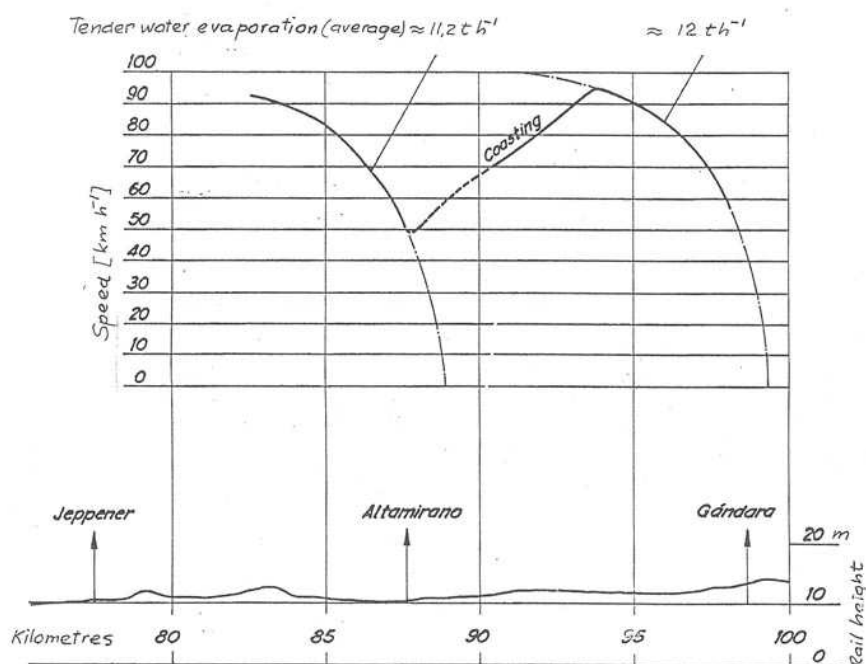

Fig. 2: Locomotive N°3477, prototype class ROBC2, FCGR, Argentina. Built in 1915, modernized by the author in 1954. Drawbar power: 1400 HP.



LOCOMOTIVE N° 3477

Acceleration test "en reprise."

Boiler load $\approx 85\%$ of maximum
Train: 11 vehicles (3 coaches, 1 tank car & 7 box cars).

Load: 440 t.

Train N° 1060 (Fish train).

Date: 16-11-55.

Road: Mar del Plata -

Plaza Constitución.

Wind $\approx 5 \text{ km h}^{-1}$, variable direction.

Fig. 3: Example of the acceleration capacity of a 1915 built locomotive, modernized in 1954 by the author (see Fig 2).

12

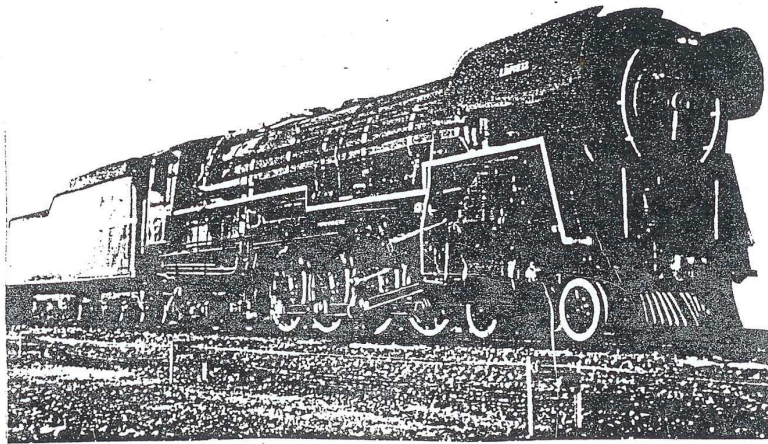
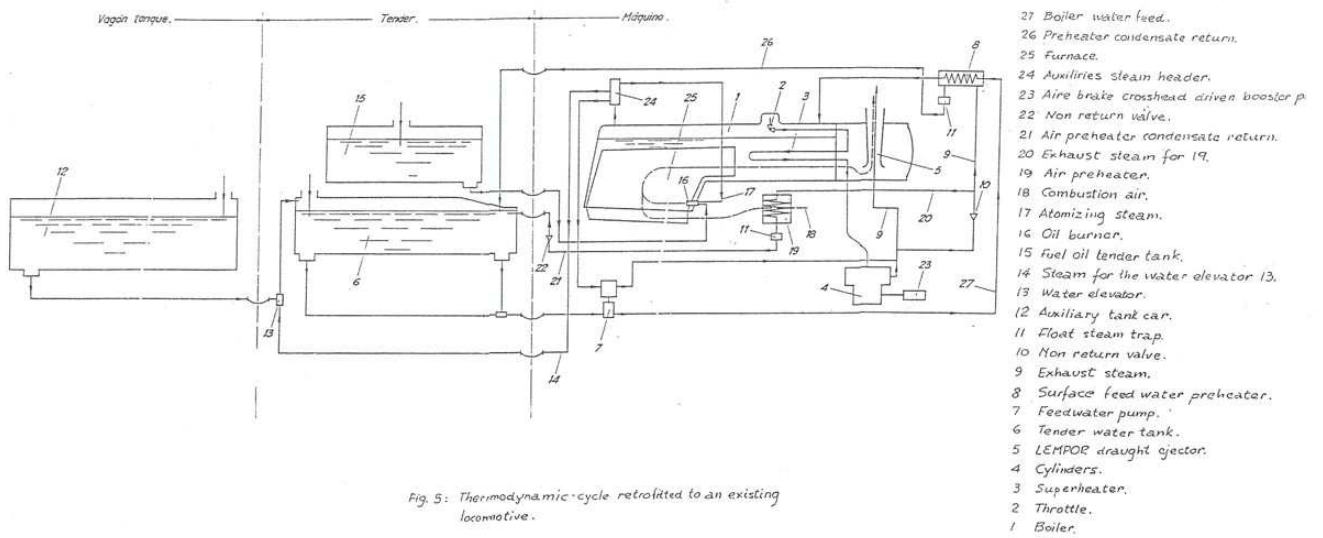

FIG. 4: LOCOMOTIVE N° 3450, CLASS 26 PROTOTYPE, SOUTH AFRICAN RAILWAYS, MODIFIED TO PORTA'S TECHNOLOGY. NARROW GAUGE, 4000 HP. AT THE DRAWBAR.



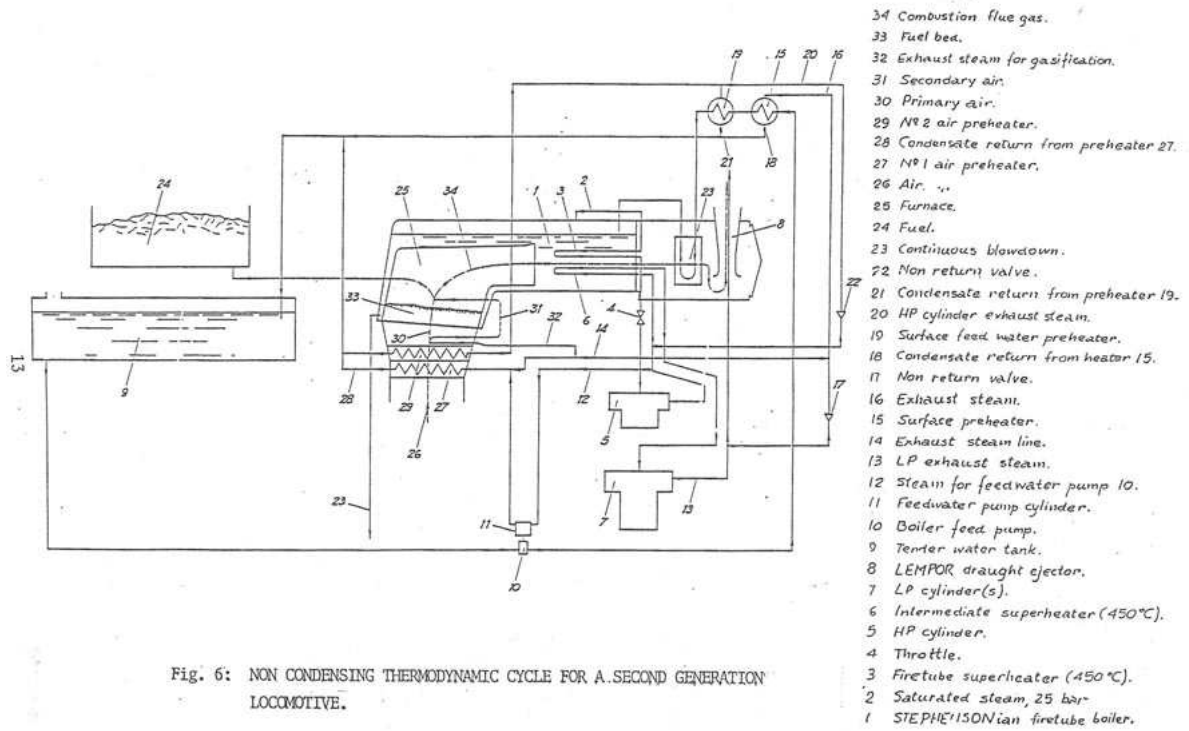

Fig. 6: NON CONDENSING THERMODYNAMIC CYCLE FOR A SECOND GENERATION LOCOMOTIVE.

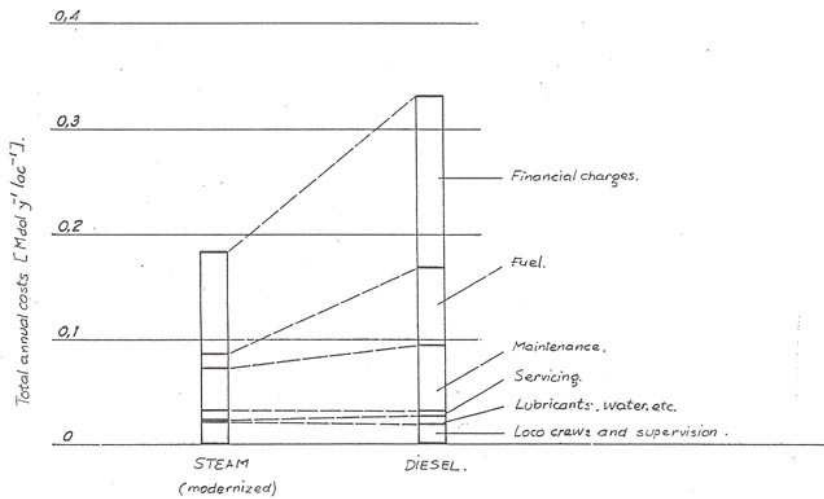
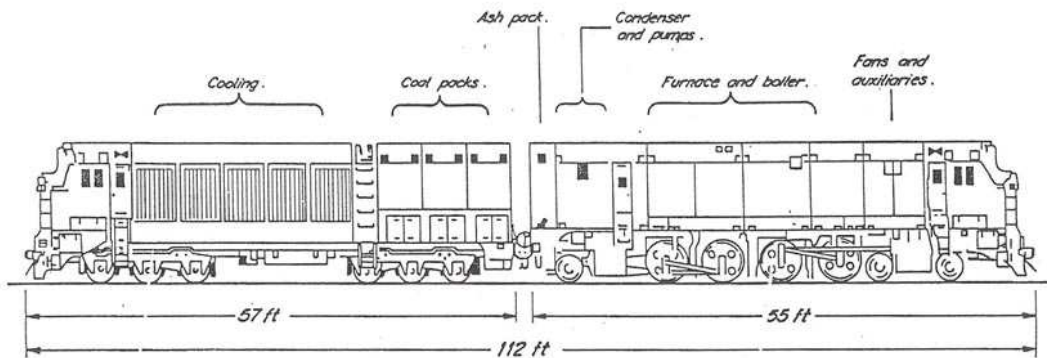

Fig. 7: Total compared annual costs for locomotive power in Paraguay. The favorable incidence of the fuel (planted firewood) and of lower financial charge is dominant



Support unit

- Total weight. 300 000 lbf
- Coal storage. 66 000 lbf
- Water capacity. 10 000 Gallons
- Cooling capacity. $35 \cdot 10^6$ Btu/hr

Power unit

- Total weight. 350 000 lbf
- Weight on drivers. 240 000 lbf
- 4-Cylinders Compound Expansion engine.
- Dynamically balanced interconnected drive.

Operation characteristics

- Unrestricted bidirectionality.
- 15-Hour range, continuous operation, full power.
- Condensing steam cycle
- Clean exhaust.
- Computer control.
- Fits railroad's clearances on 100% of U.S. track mileage.

Fig. 8 : The ACE 3000 "2½" generation locomotive. Fuel: coal (Ref.(19)).

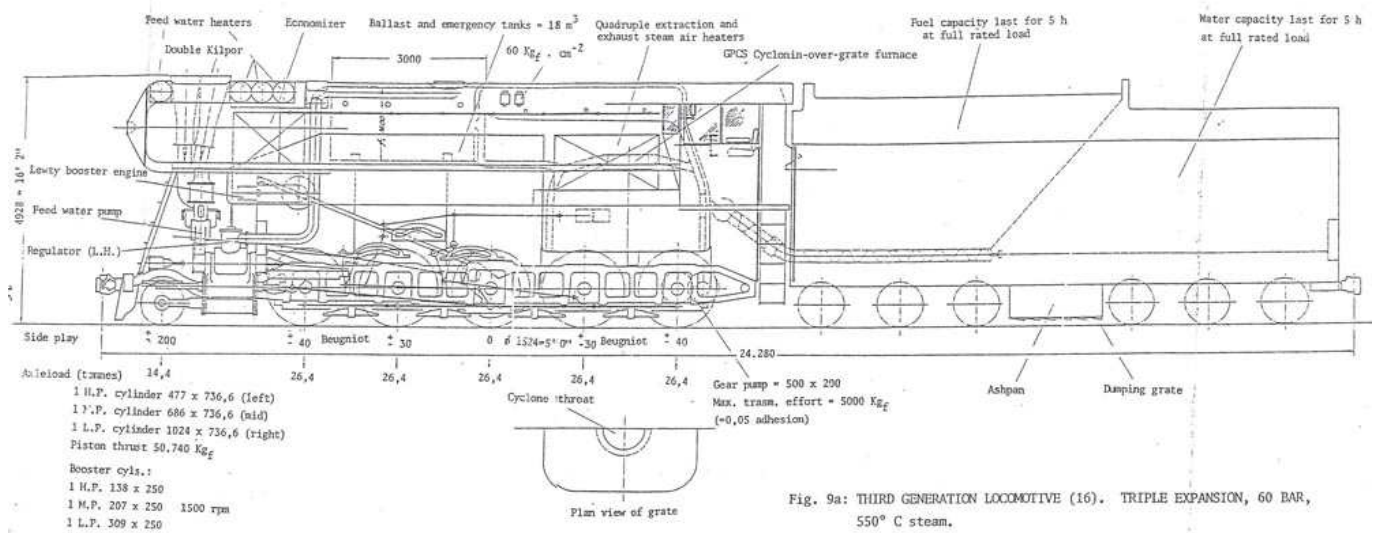

Fig. 9a: THIRD GENERATION LOCOMOTIVE (16). TRIPLE EXPANSION, 60 BAR, 550° C steam.

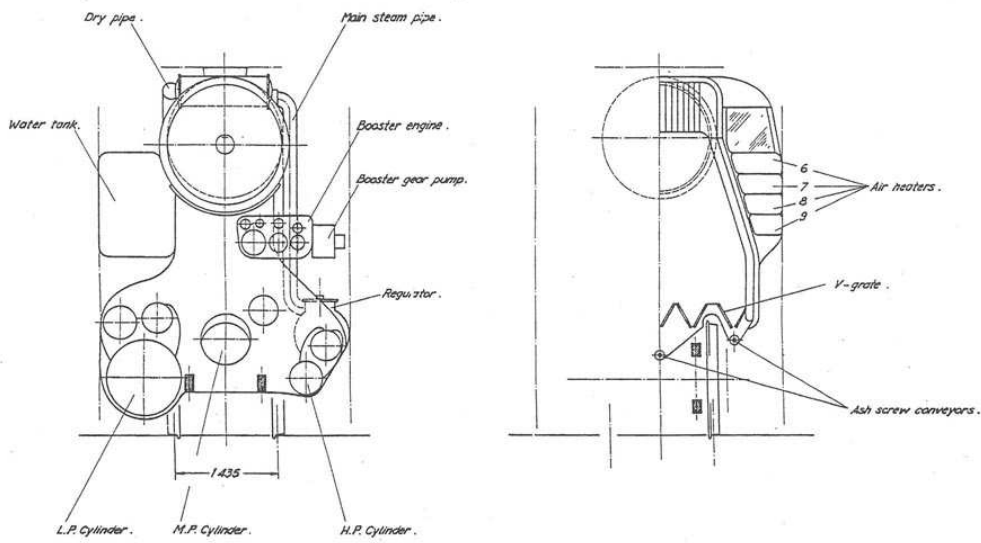

Fig. 9b: CROSS SECTION OF THE LOCOMOTIVE SHOWN IN FIG. 9a (16).

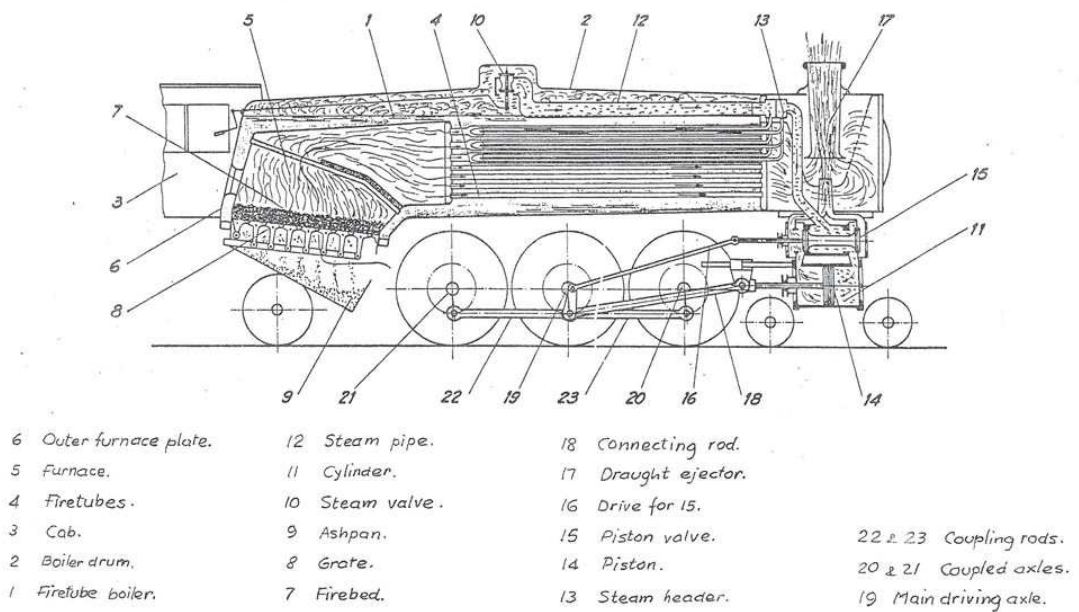
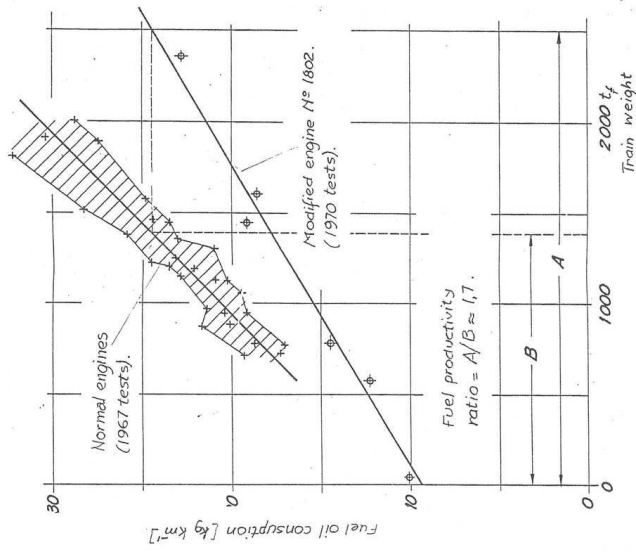

Fig. 10: Essential components of a traditional 1914 steam locomotive.



Belgrano Ry. (Argentina).
 Fuel consumption tests.
 Chaco area, flat level lines.
 Engine No 1802 modernized.

Fig. 11: Effects of modernization on fuel productivity:
 ≈ 70% increase.

All curves refer to engine in warmed up condition.

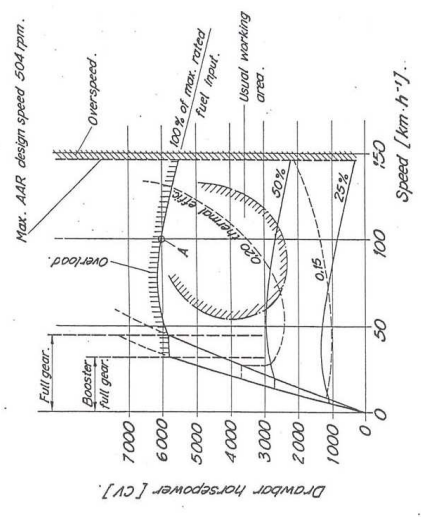

Fig. 12: Drawbar power characteristics of the Third Generation locomotive shown in Fig. 9 (from Ref. (16)). The power curve is very flat, and the usual working area is coincident with that of the best thermal efficiency. 1 CV = 1 metric HP.

- 1 U.P. 4-8-8-4 "Big Boy".
- 2 A.T.S.F. 2-10-4
- 3 Max. tractive effort, safety valves popping.

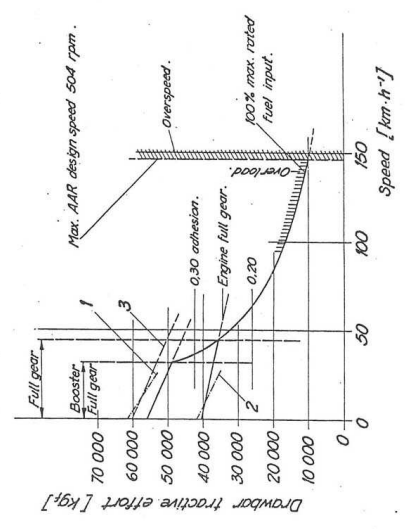

Fig. 13: Drawbar tractive effort characteristics corresponding to the power curves shown in Fig. 12 (from Ref. (16)). At low speed, the tractive effort is quite close to that of the U.P. Big Boy. The latter was an eight-coupled articulated machine.

1. INTRODUCTION

Oil is expensive, and the present price fall is nothing but an oscillation superimposed onto a rising trend motivated by the finiteness of the resource and by the increasing costs of getting it out.

Every country, whether an oil producer or not, PAYS A HEAVY PRICE for the oil used for internal consumption: if it produces it and consumes it, it cannot sell it on the international market; if it does not produce it and hence has to buy it, this is done in exchange of exports whose benefits are becoming clearly smaller.

The issue becomes complicated because the automobile civilization (from which nobody wants to quit) imposes severe constraints: until now, no workable substitute for gasoline and diesel oil has shown up. Heavy fuel oils contain increasing quantities of polluting sulphur. The demand for higher thermal efficiency leads to an increased demand for gasoil and diesel oil, which results in a disturbance of the present distribution of refined oil products. Fuel oils are becoming heavier and heavier, and very soon they will be just asphalts whose combustion is not an easy one.

On the other hand, there is a plea for using renewable energy sources: amongst them, solar energy. Shall we be able to run railways on solar energy? YES. Our grandfathers did that. LET US SOW FUELWOOD! But let us use it with 21st Century technology. Dendro energy is the form in which solar energy can provide for steam loco motive power. Dendro energy is more than fuelwood. The latter is just a part of the forest energy. Branches and leaves are now considered for possible utilization in steam locomotives of advanced thermodynamics thanks to the GPCS (Gas Producer Combustion System).

The present paper before Mexico, an abridged synthesis of the author's development work as carried out during the last 40 years, and also those which are now current in steam motive power matters - a new kind of power, having nothing to do with the image coming to us from a definitely dead past. It can use not only wood, but also coal and natural gas. Mexico has posed a question, and Argentina offers what it is believed can be useful, even if only for restricted areas. Southern Mexico has immense jungles which a bit at a time will be converted into farmlands: this will leave a fuel whose cost might perhaps be negative, yet possibly sewing for the mass transportation in the area. Northern Mexico shows coal: if used, it will leave an oil equivalent which the country will appreciate as if it were gold.

1. THE NEW STEAM POWER – WHAT IS IT?

Nothing dramatic - neither ultra high rpm, nor super voltages; nor supercritical pressures. The best comparison is that shown between the 1914 diesel engine and the present one: everything that can be rescued from an illustrious past is used, transformed, and (will be) complemented with all the advances which, coming from more progressive technologies, can be incorporated into a package whose fundamental characteristics should be consistency and harmony. And, above all, accounting for the interest and particulars of the users and their special physical, economical and human scenario. Perhaps, a most fresh example of this is the paper in preparation: "PORTA, L. D. An Essay - The Russian Approach to Friction and Wear Problems as Applied to PORTA's Advanced Steam Locomotive Technology" (Ref 1)

AN OVERALL VIEW

Three stages may be distinguished in steam power technology:

- (i) First Generation Steam: the one which reached the climax by the 50's. CHAPELON in France was its champion on the thermodynamic side, while the Americans were on the mechanical side;

- (ii) Second Generation Steam: the one which can be materialized today at commercial level applying the PORTA technology as silently developed by the author after 1950 (Ref 4), and
- (iii) Third Generation Steam: the one which may be materialized through a research and development program applying technologies that are waiting to be incorporated.

There should also be mentioned a fourth category of interest for the world which still run by existing First Generation Steam Locomotives, most of which do not incorporate all the advances that could have been. This is the MODERNIZATION technique consisting in the partial application of Second and Third Generation principles as far as consented by non-structural modifications. In all cases, an essential ingredient is the idea of TECHNOLOGICAL PACKAGE (section 2.5).

Appendix AI shows a short description of what such a First Generation locomotive was, and makes reference to condensing. The traditional locomotive is an open cycle machine, namely that the steam having worked is exhausted to the atmosphere, or at best, some 15 to 17% is recirculated. The author proposes condensing by means of air cooling (direct or evaporative) only for Third Generation machines that are to operate in a physical (desert) or in an economic scenario that makes it worthwhile. Meanwhile, he adheres to the open cycle which may require: (a) taking water without stopping (Pennsylvania RR, England) or (b) enough on-board reserves to run stretches between mandatory train stops. This is possible because the considerable increase in the thermal efficiency leads to such a low water consumption that it can be one third of that of a traditional locomotive. Water quality is indifferent because it can be easily treated on board.

The fuel may of course be fuel oil or even asphalt within a very ample specification. In the PRESENT state of the technology, coal whose quality range can extend considerably beyond that traditionally accepted, may be used. Fuel wood of any kind, including branches and leaves, can be used either in manual or mechanized firing. There are developments in course aiming at reducing fuel size, calorific power, swelling index, moisture, etc. requirements, even if locomotives may not be the proper place to burn low quality fuels because a high price must be paid for carrying it on board and for the highly increased handling costs. Compressed natural gas also enters in the spectrum of usable fuels.

The global scheme explaining the sensible progress carried out with respect to the traditional steam locomotive (about which it has taken for granted that it had reached a development climax imposed by the fundamental laws of physics) results from the MULTIPLICATIVE and integrated effect of the following factors:

- (a) the thermodynamic cycle of the theoretical heat engine has (i) enlarged bounds (pressures, temperatures, etc,) and (ii) new elements, some of them pertaining to power station practice: regenerative cycle, air heating and even condensation;
- (b) the efficiency of the real, practical machine has been increased either (i) because the various losses are reduced or (ii) because those which are constant are diluted into a larger steam flow which the engine can "breathe" thanks to the advances achieved in internal streamlining;
- (c) the overall "annual" efficiency of the locomotive as a machine for pulling trains is augmented through minimizing the losses associated with the intermittence inherent to railway operation;
- (d) the productivity of the investment is increased thanks to the virtual elimination of those factors impeding an indefinitely continuous working (e.g. firebed clinkering or heating surface fouling);

- (e) environmental protection is duly attended (smoke suppression) sparks and dusts, etc.
- (f) And, last but not least, the traditional machinery is kept, requiring just one tenth of the accuracy of the diesel counterpart. This presupposes lower investment and maintenance costs, and less demanding driving and handling practices.

THE THEORETICAL HEAT ENGINE

The open thermodynamic cycle if the traditional locomotive has been enlarged:

- (a) upwards, with steam pressures reaching 25 bar for Second Generation machines, and 60 bar for Third Generation ones. Steam temperatures attain 475°C in the Second Generation and 550°C in the Third Generation, always keeping to the reciprocating engine;
- (b) downwards, with very low back pressures thanks to the LEMPOR draught ejector developed by the author;
- (c) in "other directions" thanks to the "tricks" which in power station practice are known as "regenerative cycles" (see appendix A3).

Concerning condensation, the author prefers the evaporative scheme developed by ZOELLY-ESCHER WYSS in 1919 (Refs 5 & 6). Even if there is a definite water consumption, this is so small that it is compatible with such long distances between watering points that they are equivalent to virtually zero water requirements en route. ZOELLY - ESCHER WYSS proved that it was possible to obtain 85 to 90% vacuum with the technological resources of their time.

It is to be remembered that the basis for the increased thermal efficiency is to be sought in the Second Law. Namely: that it is necessary to reduce the entropy increases of the system where the calorific energy degrades itself into irreversible transformations without producing external work; principle which is also valid for the real heat engine. This, as old and elementary as thermodynamics itself, has NEVER been explicit in First Generation Steam technology.

It also belongs to the theory that irreversibilities are somewhat "recoverable" (or at least not so serious) if they occur in the "upper" part of the evolution, where pressures and temperatures are high; while they are definitely lost if they occur in the lower part of it. Hence the tremendous importance of internal streamlining in everything concerning exhaust steam. This point was not fully understood in the past (especially in the United States), and it is mentioned here to explain the reason for the apparent climax supposedly imposed by the laws of nature.

Concerning the power that a locomotive is capable of, two fundamental laws are:

$$\text{Power (kW)} = \frac{\text{Steam Produced by Boiler [kg/h]}}{\text{Specific Steam Consumption [kg/kW/h]}}$$

and

$$\text{Power (kW)} = \text{Heat Input [Gcal/hr]} \times \text{Thermal Efficiency}$$

(Note: non homogeneous units are used for better illustration.)

These two equations are as old as thermodynamics itself, but neither were EXPLICIT currency in the past. A claim is also made here of a warning given about their essentiality for understanding what a steam locomotive is, as late as 1975 (Ref 7)!

The importance of the first equation lies in that, even if it is true that in order to obtain a given power one can work on the numerator (the American style with enormous boilers), it is also true that acting on the denominator an equivalent effect is obtained. In the case of the First Generation Steam, the aim towards the lowest steam consumption was understood rather under the concept of economy, an economy not of great interest in cheap energy times. In the second equation, it is also clear that in order to obtain a given power, one can work on the first factor (again the enormous American boilers) but also on the second one. Here, it was not either seen that thermal efficiency was something more than "economy" - a poor understanding contributing to explain the falseness of supposing that the climax of the '50s was imposed by physics. This unauthorizes those who said that "thermal efficiency never sold a single locomotive". In fact, anything increasing the thermal efficiency should translate into increased economy per hauled ton-km and/or increased power.

Appendix A2 details the main elements which, deserving the qualification of new, have been incorporated to the herein-concerned technology. In principle, all of them keep to, or participate of, the NATURAL AUTOMATISM of the STEPHENSONIAN conception of the traditional locomotive.

The author prefers not to work with the principle stating that the final thermal efficiency is the product of the partial efficiencies (theoretical cycle, boiler cylinder and mechanical efficiencies), not because it is not true, but because its application is not simple when complicated thermodynamic cycles are analyzed. Besides, it does not show in a simple manner how to take advantage of irreversibilities occurring in the upper parts of the cycle, and how it is possible in the practical machine to materialize thermodynamic evolutions leading to fewer irreversibilities. Also, in order to use the principle, it is necessary to redefine the above partial efficiencies.

2.3 THE REAL HEAT ENGINE

The real heat engine materializes the theoretical heat engine. To do it with minimum losses is an essential objective even in a zero-fuel-cost hypothesis. In order to achieve it, it is necessary to have a thorough understanding of the theoretical heat engine. In the past, this point was not fully apprehended, particularly, in the English speaking countries, where the dazzling simplicity of a piston which is pushed by steam pressure impeded to see, for example, the enormous importance of the utmost cylinder insulation, a point which the stationary engine brotherhood was fully aware of and pursued with endless care. Thus, the shunting (switching) engine was a heat engine never thought of under such optics.

The titles of the herein included literature show what have been the author's concerns in these aspects. In doing this, he has but followed what has been indicated by power station and diesel engine techniques.

The author has also developed an endless number of "tricks" oriented towards making the real engine approach as much as possible the theoretical engine. One of them, for example is using "diesel" piston rings.

Combustion is an important point. The coal or wood burning traditional locomotive has paid a high price for the necessity of achieving high combustion intensities in necessarily small furnaces. That price has been the emission of enormous quantities of unburned carbon and sparks. The GPCS (Gas Producer Combustion System) is an answer to that problem. It consists of converting the grate into a gas producer; the gas is burned in the combustion

space thanks to a high proportion of secondary air (70%) animated with strong turbulence. The latter is produced by a strong draught induced by a highly efficient LEMPOR or KYLPOR ejector, both original author's inventions. Injecting a certain proportion of exhaust steam together with the primary air, smoke disappears. These are serious prospects that the system will be able to control both SO_x and NO_x emissions. The GPCS system also works very satisfactorily with fuel wood and vegetal residua (Ref 11). The steam injection allows the use of coals showing fusible ashes without clinker formation; thanks to a continuous ash discharge, it is also possible to obtain continuous steaming. Because there is no smoke or tar, the firetubes are kept indefinitely clean. There is neither heating surface nor ash fouling.

An essential point of the new technology is that the engine maintains its performance unchanged between shoppings. In this connection, the most important factor is to keep low and constant the steam leakage through piston rings and gland packings - this is achieved thanks to techniques current in marine internal combustion engines. A careful redesign of details which in the past failed along the kilometrage, has permitted their correction. This also leads to think that Third Generation problems will be solved the more easily, the greater the money available for research and development to be charged to a large number of locomotives.

Boiler feedwater, that caused so many difficulties in the past, ceased to be a problem shortly after WW2 (Ref 12). Recent studies by the author (Ref 13) lead to suppose that the extremely simple carbonate internal treatment is also applicable to Third Generation locomotives with pressures up to 60 bar (850 psig).

A new understanding of the role of steam expansion has permitted to reformulate the old question of compounding: thus, all of author's designs are compound, even for shunting engines.

The real heat engine must get as close as possible to the theoretical heat engine, this depending less and less from the drivers feelings, who are now assisted by instruments and training courses so that they only have to add the final refinements to their driving work. As a matter of course, Third Generation machines must be fully automatic.

In the past, the thermodynamic performance of the real heat engine very much depended from a kind of maintenance methods (in the SNCF style) which leave very little margin for decisions at the lower echelons. In the future, maintenance is foreseen as a spare part replacement process. An important point is that of TRIVIAL maintenance (loose bolts, leaking joints, minor breakages, etc.) which in the past took 50% of maintenance man hours, This has also been overcome thanks to a careful re - design of details.

Appendix A3 describes a non condensing cycle for Second Generation machines.. Its thermal efficiency at the drawbar is 17% when measured on test at 2/3 load and 2/3 of maximum speed. This figure varies very little over a wide range of powers and speeds; it corresponds to 27% obtained in the case of a good diesel locomotive, but the difference lies in that the steamer uses a THREE TIMES CHEAPER FUEL. The cycle includes all refinements which make possible to obtain a maximum efficiency within a Second Generation Scheme. This implies the use of knowledge and experience is available TODAY. In (Ref 16), the author extends the pressure and temperature limits showing that, without calling for condensation, it is possible attain 21%. Some exploratory calculations show that including the latter it is possible to get 27%. But in this case, it must be demonstrated that fuel economies compensate for the higher financial and maintenance charges.

Fig. 5 shows a cycle studied for an existing locative under a modernization scheme.

2.4 SYNTHESIS.

A good locomotive is the one making plenty of traffic with a minimal expense. And a good motive power is the one permitting the commercial department of a railway to operate on the transportation market with aggressive, competitive services. It would not be the first time in history that motive power advances have CREATED traffic. This is possible if the theory is materialized in a happy practice. As a matter of course, "kitchen recipes" are not enough for substituting the engineer's talent, but they help. The steam locomotive is a very simple machine but one which "withstood" during a century a correct understanding, only culminating in Great Britain after the WW II, particularly after the well-known works of ELL.

This synthesis has a full meaning under the comprehensive concept of INTEGRATED TECHNOLOGICAL PACKAGE. This is not just buying or selling machines that in the past users operated, and whose problems they had to solve WITHOUT HELP: now what is transferred is a technology including spare parts, training, maintenance techniques and equipment, etc., and even the manufacturer's assistance for the solution of questions associated with unforeseen circumstances. The user, therefore, dedicates himself to do what is specified for a railway: TRANSPORTATION. This concept, developed by diesel power, particularly the American one, permits for a few locomotive designs to cover a large service spectrum, with which it is possible to have an important technical effort aimed at improving reliability in service. In this respect, details play a most essential role.

When boiler maintenance ceased to be the component defining heavy repair cycles thanks to the now available (very simple) water treatments (Ref 12); and having the motion able to run lengthy kilometrages without wear, thanks to roller bearings; and because of piston rings lasting five, perhaps ten times more than in the past (Ref 10), tyre reprofiling remains as the factor forcing locomotive overhaul, say, every 200,000 km. But, even in this point, in Argentina, a development is in course permitting to remove this condition. It is a tyre grinding machine which - every month returns the tyre profile to drawing dimensions. This is carried out without dismantling motion, with the engine on steam, and in some 8 working hours. It leads to double tyre life and because the profile is kept to dimensions, adhesion qualities remain unaffected. Optimistically, it is possible to think that overall engine wear may, perhaps, be reduced to one fifth of that of the past (Ref 14).

Concerning investments, it should be noted that they were (at least in the USA) about one third of the contemporary diesel for the same power (Ref 14). This cannot be said today because diesel technology has made progress. But it is also to be expected that steam will follow a similar path, therefore re-establishing the previous relative position. There are some definitely favourable factors, namely:

- (a) a steam locomotive is largely simple boiler-smith work,
- (b) the machinery demands a lower accuracy,
- (c) materials qualities are less exacting, etc.

It is also possible to use compressed natural gas or liquid natural gas if it is so convenient. The essential point is that **no structural changes are necessary on the boiler** in order to burn any one of the herein mentioned fuels. Of course, each one of them requires a particular set of appliances, but in any case it is possible to make the change over in 24 hours. The equipment serving for mechanical fuelwood firing is the same used for coal.

A great advantage of steam power is that it does not depend on liquid fuels. Even if bunker C is used, its lower price (some 30 to 50% compared to diesel oil) compensates for the lower thermal efficiency. Even more: steam power can work on asphalts solid at room

temperature, and the higher sulphur contents do not lead to corrosion phenomena in the boiler even if no precautions are taken.

2. NO OIL FUELS

The great alternative is of course coal. This has prompted the USA to seriously explore the possibilities of steam (Ref 19). The small amount of oil still available to the world must be preserved for those uses where it cannot be substituted, and railway motive power is not precisely one of them. As in the past, trains can be run on coal, now without any impaired performance thanks to the new technology.

The price of coal must be related to the price of oil on a calorific base including self transportation costs, and with the fuel consumption necessary to perform a given transportation duty. Since these consumptions are no longer seven times higher than was the case for steam (as in the USA in 1950), and since the cheap oil era has finished, calculations must be reworked. As an illustration, taking some fuel prices prevalent in that country before the present (1987) oil glut, one may have:

$$0.85 \text{ US\$ /gal} \times 260 \text{ US\$ gal/t} = 221 \text{ US\$/t (t is for metric tonne)}$$

For a coal price of 40 US\$/ton = 44 US\$/tonne, it is on a calorific parity:

$$\frac{44 \text{ US\$/t} \times 10,200 \text{ kcal/kg}}{7\,000 \text{ kcal kg}^{-1}} = 64 \text{ US\$/t}$$

Considering 0.21 and 0.11 as system thermal efficiencies for diesel and Second Generation Steam, it is:

$$64 \text{ US\$/t} \times \frac{0.21}{0.11} = 122 \text{ US\$/t as compared to 221 US\$/t for oil.}$$

This implies that in a first rough approximation, fuel costs can be reduced by one half. Given that in that moment fuel costs were = 16% of the total (railway) expenditures, if they were reduced to 8%, the net earnings would increase from some 11 to 26%, a substantial 50% augmentation (Fig 7) which is far from negligible if the remaining costs are substantially the same. Under a similar scheme, should Mexico import coal from the USA? How much coal is there in Coahuila?

Fuelwood can show surprisingly favourable costs for certain local scenarios. Thus, for instance, in the case of Paraguay they are SEVEN times lower compared to the equivalent gasoil for a given service carried out with existing modernized locomotives (Ref 15).

In the case of low powers and in labour-intensive countries, manual firing is acceptable. The aim is to develop mechanical firing and processing from the wood (plantation) to the firebox, in which case all (or nearly so) of the bio-mass can be taken advantage of because branches, leaves, bark, etc. can be used with full efficiency.

The use of fuelwood, which is to run trains on SOLAR ENERGY, must in any case be conditioned by two measures of public order:

- (a) woods usable for construction must not be utilized, and
- (b) the ecological equilibrium must not be upset.

Both conditions are respected if special fuel wood plantations area provided. For example, the BRACATINGA (Mimosa scarbrella, BENTH) under certain favourable climatic conditions shows an extremely rapid growth: three years (Fig. 1). The author is presently studying some techniques for accelerating natural drying, and also mechanical bulk handling.

3. EXAMPLES.

It is not enough to offer principles, calculations and ideas about a proposed motive power whose center of gravity is to be placed in the next coming years: it is necessary to show how these principles, calculations and ideas are materialized in hardware. From the large spectrum of possibilities answering with greater accuracy the demands of each physical, economical or social scenario, some examples are extracted which, in the case of modernized locomotives, have a real existence.

Fig. 8 shows the ACE 3000, an American project on which the author had a relevant participation. It is an intermediate machine between the Second and Third Generation Steam. It includes condensation and automation, and satisfies a large number of environmental requirements.

Fig. 9 describes a Third Generation 2-10-0 engine proposed by the author in 1978 for American fast freight traffic. What makes it a Third Generation machine is the thermodynamic cycle-elements. Automatic controls based on micro-processors and a full answer to environmental requirements are yet to be contemplated. Its rated drawbar horsepower is 6000 HP. Figs. 12 and 13 show the characteristic curves. It is a non-condensing machine whose thermal efficiency attains 21%; in order to achieve this figure, steam at 60 bar pressure (850 psig) and 550°C temperature (1022°F) is used in a triple expansion engine. The latter results from placing an additional high pressure cylinder before a Second Generation compound group. As it is seen, the author has been able to keep the design within a traditional configuration whose success is supported by the test of the time. Why should it be changed?

Fig.11 translates into an abridged synthesis the practical results of a light modernization. It is seen that fuel productivity is about 70% greater.

4.1 MODERNIZATION OF EXISTING LOCOMOTIVES.

The theme of modernization is not a new one. CHAPELON (3) in France traced paths which only in Argentina were taken into account (4). The CHAPELONian modernization essentially consisted in removing thermodynamic irreversibilities and in increasing the energy input per unit of time which the machine is able to take thanks to a better internal streamlining. The world still has some 20,000 steam locomotives amenable to receive the partial application of principles used in full in new designs. The author has carried this out in a dozen designs, and with his technology, WARDALE in South Africa. (20), GIRDLESTONE in Great Britain (21), BUTTERWORTH in Sweden, etc. have substantially improved the performance of another half dozen. An essential point of the modernization is the application of the GPCS (4). The author has also improved a large number of thermodynamic and mechanical details so as to increase the machine's robustness and reliability.

A typical example of modernization was engine N° 3477, FCGR, Argentina, prototype of class R08C2. Built in 1915 for suburban services with a drawbar power of about 800 HP, after the modernization it reached some 1400 HP. Its acceleration with six coaches was comparable to that of the electric services of the FCGBPM of Argentina (Figs 2 & 3). Another example is that of engine N° 3450, prototype of South African Railways class 26, modernized by D. WARDALE. Its power passed from 3000 HP to 4000 HP without introducing structural changes. Note that it is a narrow gauge machine with just 18t axle load. WARDALE is presently (1987) working in China to improve the power and economy of the QJ design, the former passing from 3000 to 4500 HP.

How is it that such increases in power can be taken by the existing engine structure? Because most of it is designed to support forces which do not significantly change: for example the springs.

4. MOTIVE POWER POLICY.

Each form of motive power, from the horse to the yet not invented locomotive, has its field of application dominated by two large factors: (a) the traffic intensity, and (b) the characteristics of the economical scenario. Thus, the horse continues to have a place to move wagons one at a time in isolated stations; the simplified steam traction in neighbourhood or plantation railways; the traditional steam power in low or medium trafficked areas; and electrification for large massive transportations. Each application zone interferes with its neighbouring ones so that the choice requires detailed analyses. Since at the bottom, total costs are decisive, the factor making up the economic scenario (including imponderables valuate in money terms) become important. These vary (i) from one country or region to another, and (ii) they change with time. Hence, general assertions terminating in false commonplaces cannot be made - one cannot say that "electric traction is better than diesel". For, whilst Europe electrifies, the USA does not.

In this context, the herein spoken steam power includes, as elements leading to the invasion of until now "forbidden" areas, the following factors which reduce the total costs, namely:

- (a) the possibility of extending the range of maximum performances: very high powers concentrated in a single unit - for example 25,000 HP in the Super-GARRAT configuration proposed by DURRANT; high speeds proposed by CHAPELON (3) and by PORTA (22); multiple unit working, etc;
- (b) the high power-to-engine-weight ratio (for example 28 HP/t (CHAPELON), 45 HP/t in latest proposals by PORTA, etc) thus improving the acceleration and uphill performance and reducing the investment required for a given power;
- (c) the use of lower quality fuels (hence lower prices) and, as a matter of course, the ability to work without oil and on solar energy;
- (d) the possibility of achieving high performances without recourse to costly materials and/or high manufacturing or maintenance accuracies;
- (e) the transference of the largest possible number of intelligent decisions to the upper ranks of the railway (not at train driver or shed mechanic levels) and to the manufacturer, both possessing more information;
- (f) quantity production, etc.

In parallel with the above, there has been an evolution in the economic scenario, namely:

- (i) liquid fuel costs have risen up, hence stimulating their substitution by coal, fuelwood, biomass, etc.;
- (ii) the capital/labour cost ratio has changed; interest rates (in hard currency) continue to show the historical rising trend;
- (iii) the cost of imported components, spare parts, etc. increases for Latin-American countries in direct proportion with the lowering of the raw materials they export, etc.

The moral is that the moment has arrived where everything should be revised and new studies be done accounting for the above concepts.

5.1 FUTURE DESIRABLE PERFORMANCE.

What should be demanded for advanced steam power? First, that it does not incorporate those features which, in the past, involved psychological and physical effort and stress. That driving a train should be a pleasant activity which offers a degree of driver participation exceeding a mere button-pushing. In spite of all what may be said, driving a steam locomotive always produced what cannot be provided by "impersonal" diesel or electric machines. Because of that, it has been proven that the latter are more tiresome. But, what concerns here, is that such satisfaction be a more refined one as a consequence of the man concurring to optimize the service - which is far from negligible.

It is also possible to do same work with maintenance operations: instead of the dirty and dark roundhouse of the past, there must be a clean servicing workshop, and even cleaner than a diesel one because it would be free from the all-invading gasoil. In that context, a modular, air conditioned cab is a must.

High power-to-weight ratios, as is the case for electric locomotives, pose maximum demands to adhesion. Today, numerous resources which lacked in the past are available - these substantially coming from the electrical world (Ref 23). Of course, the important factor is rail contamination. In this connection, the disappearance of diesel locomotives from a given area is to be desirable in view that they are heavily rail polluting (Ref 24). Also, those high massic[?] powers, together with higher boiler pressures, lead to a more "nervous" behaviour of the boiler: reaction times are now to be measured in tens of seconds only. In this connection, the locomotive boiler is unsurpassable thanks to its natural STEPHENSONian automatism (Ref 25). But now the case demands much better driving instructions and even a partial automation for Second Generation locomotives.

There is a fundamental change concerning the shape of the tractive effort curve: the substitution of roller for plain bearings in the cars has eliminated the need for a high initial tractive effort in order to compensate the great friction obtaining at low speeds, especially in winter. The internal streamlining and the compound working lead to a flat power curve at the various speeds (Fig 12) as opposed to the traditional "parabola". All this makes the steam locomotive a "machine for power", not one of high tractive effort at low speeds. As is the case with the electric locomotive, the train which it can pull uphill will be run at a good speed, approximately 40% of the maximum designed for. This permits (a) to play with inertia grades, and (b) to increase line capacity. When the design is not subjected to the limitations inherent to diesel power, the uphill speed at the limit of adhesion is about double: example, electric locomotives for the British Columbia Railway (Ref (26), p.741).

Concerning operation, it should be noted:

- (i) the possibility, today, of doing 2000 km without nursing; in the case of non condensing machines, the distance run between watering points can be that corresponding to crew change points, while there is no difficulty in making 1000 km between fuelling stops;
- (ii) keeping the boiler under pressure without enforced watching when the engine is in standby condition. Also six months under steam;
- (iii) one man driving;
- (iv) full bi-directionality, etc.

5.2 MOTIVE POWER COSTS IN THE FRAME OF PUBLIC BENEFIT.

All, or nearly all, railways in the world operate at a deficit according to the conventional accountancy. But all of them invest huge amounts of money every year in expansion program (38,000 M\$ in 1978). How can such investment be explained in enterprises working

at a loss? The answer is that conventional accounting shows neither the effort nor the benefit that railways provide to the community. These give a benefit now perfectly expressed in quantitative terms, which can be incorporated to their accountancy: this has been designated as "Public Benefit" (Ref 17). This results from avoiding all the expenses that would be incurred if all the railway traffic were carried by the alternative transport modes (road transport). In some way, it must clearly be shown that the latter, with its lower energy efficiency, its greater requirements of human effort, and its impossibility to make-up enormous transportation units (trains) driven by a single person, cannot be competitive of the railway in mass transportation. This accounting system is the "transparent" accountancy which comprises the traditional accountancy.

Each country, with its economical, technological and social circumstances, shows a particular reference frame for the evaluation of that Public Benefit. When considering them, investments in motive power should be viewed in that frame. For example, in the case of the Argentinean Railways whose traffic is largely conditioned by the available motive power, each additional locomotive in service leads to a Public Benefit of the order of \$5m per year. Above a minimum traffic threshold, the Public Benefit that railways give to the community is an "exponential" function of the traffic. Thus, it is understandable why in that country there is a strong pressure to invest in locomotives. The drama is that is also a demand for other investments or, what is equivalent, to insure for them a HIGH RETURN COMPARED TO ALTERNATIVE SOLUTIONS.

A railway has, as a function inherent to its nature, the obligation of maximizing the Public Benefit. Once it has been decided that investments are to be made, their optimization is not a simple problem, but the one offering the highest rate of internal return is the one to be preferred. This return can be infinite if lower operating costs can be obtained with smaller financial charges. That is the case of Paraguay (18) in which the modernization is carried out with only 60% investment of the equivalent diesel alternative (18) and whose total costs are roughly in the same proportion. This is essentially due to the fact that fuel costs (fuelwood) are SEVEN times lower and that financial and maintenance charges are also lower (Fig. 7).

5. CONCLUDING REMARKS AND RECOMMENDATIONS

It is impossible to describe in a short paper what the NEW steam technology is. Today's railway executives have just a vague idea about past steam to which they (rightly) associate with smoke, dirt, painful human effort, inefficiency, difficult maintenance, craftsmanship, etc. That background lacking, it is very difficult to explain the why of a progress hitting against the firmly established idea that classical steam ended did because its possibilities were exhausted. Everybody in the railway world is familiar with diesel technology and also with the electrics, but at best they have only some idea about what is power station steam - the closest relative of steam locomotives. The idea of a machine about which it is only understood that it has cylinders, but about which one cannot understand why it has no turbines and makes no recourse to electricity, and that it also has a boiler subjected to such high pressures that if it explodes produces the effect of a high power bomb, that idea is a substitute for the level of knowledge required for decisions that lead to action. Lack of knowledge always engenders fear, which is always the fear of the unknown. Perhaps because of that the best result from the 1984 January tests carried out on the Chessie system with N614T has been that a crowd of newspapermen and women, politicians, technologists, executives, old men and clergymen could see, smell, photograph a traditional locomotive in bone and flesh. Its boiler did not explode, horses were not frightened when she passed on, she did not derail. Neither was she stopped by snow when, during one month, she pulled commercial trains as she had last done in 1948.

How to present the steam case so that Mexico does not leave unexplored its potential benefits? It is not easy. At the bottom, the problem is to cross the credibility barrier. What for the author is taken as fully known and granted, for the Mexican railway planner is a matter of conjecture. There cannot be decisions without a thorough understanding. But also there is not (there cannot be) an accelerated steam traction course, be it the classic one, or the most advanced one whose development has not yet reached beyond paper. Nor can it be bought: not today, perhaps tomorrow. Today everything is bought already made! Fortunately, Mexico has made the proper question: (a) it thinks in a far reaching future, and (b) it puts on from the very start an initial quota of credibility when asking about "developing technologies". It presupposes that where a given proposal has reached the forum of Guadalajara, presented (as in this case) by one of the invited countries, it is because it has merits enough for them to TAKE A CHANCE!

After many years of struggle in search for credibility, the author has the feeling that the steam battle should always be started afresh. And it is so because of three reasons: (a) there is not, in general, a "buying mentality". Only a few people are prepared to look ahead for new ideas and with the will of putting from their part what is required to make them successful; (b) the vacuum of knowledge about steam is so large that it cannot be filled up within the scarce time devoted to the hastened business of today, and (c) so much has been done to discredit steam, that nobody can think that the image of something dirty, inefficient and bad smelling can have another side of the coin. "Mundus vultus decepti" (the world wants to be deceived) said the Romans. That is why the ACE 3000 has a cowling for disguising purposes (Fig. 8).

Even the longest trip requires a first step. It is implicit in the invitation formulated in this opportunity by Mexico, who is going to analyse all proposals. Concerning the present scheme, it seems obvious that a feasibility study should be made looking for the potential of advanced steam power in the context of the progress of Mexican railways and their integration into the country's transportation. That study will show:

- (a) that advanced steam solutions require smaller investments;
- (b) that those investments are mostly made in Mexican currency;
- (c) that steam maintenance is easier and cheaper than the diesel one, and that it also can be done in Mexican currency. Thus, the country is not forced to acquire spare parts that must obligatorily be obtained from foreign countries;
- (d) that steam is less vulnerable to poor handling or to casual mishandling;
- (e) that any fuel can be used with easy convertibility according to availability, price or energy policy most convenient decisions;
- (f) that there is always a "steam answer" for any traffic demand, etc.
- (g) The following table shows that steam is again "in the running".

Steam scheme	First Generation	Diesel	Second Generation
Thermal efficiency %	10		21
Massic Power HPe/t	35		40
Fuel	First Quality Coal		Any Coal, Fuel Wood and biomass
Initial Price \$/HPe	350	1000	250
Total Comparable Costs \$/HPe-km*	100	100	60

* Relative units - diesel = 100

6. Appendix. A1 -- THE TRADITIONAL 1914 STEAM LOCOMOTIVE.

This purpose of this very short description is to give an idea which can be complemented by any encyclopaedia. Fig. 10 shows a firetube boiler consisting of a cylindrical shell (2) in which water is boiled thanks to the heat of the combustion gases flowing through the firetubes (4). These gases are produced in the furnace or firebox (5) made from steel plates and surrounded by circulating water contained in the space between them and the outer steel casing (6). At the bottom of the furnace (5) there is a grate (7) on top of which the fuel bed lies (8). When the grate (7) is shaken, the ashes fall in the ashpan (9).

The steam produced around the firetubes (4) and in the space between the firebox steel plates, thanks to fire radiation heat, flows through the main steam control valve (10) and, before working in the cylinders (11) (only one shown), is divided into a large number of small superheater tubes located inside the firetubes (4). After the superheated steam is collected in the header (13), it goes to work in the cylinders (11). In these, a double-acting piston (14) reciprocates. In order to control the steam inlet and outlet, there is a special valve (15) driven by the valve-gear mechanism (16). After working in the cylinder (11), the steam exhausts through an ejector (17) which creates a partial vacuum inside the smokebox thereby drawing the combustion gases through the firebed and pulling them out to the atmosphere.

The piston (14) is connected by means of a rod-and-crank linkage (18). This drives the main axle (19) whose bearings are located on the locomotive frame (not shown). There are other axles (20) and (21) which receive power from the main axle (19) by means of coupling rods (22) and (23).

The boiler works automatically because the combustion intensity on the grate (7) depends on the amount of air drawn through the fire by the ejector (17). This is so designed that when there is a greater steam consumption, more combustion air is drawn so that more fuel is burned: in that way, a stable equilibrium is obtained between steam consumption and production.

The transmission of the piston force to the wheel cannot be more simple and straightforward: there is no electricity and no gears thus leading to very high transmission efficiencies (95%).

The water required to feed the boiler, later converted into steam, is introduced in the latter by means of injectors or pumps, and is carried on a special car known as tender, which also transports the fuel.

There are locomotives in which the exhaust steam, instead of going into the atmosphere, is sent to a condenser similar to a large automotive radiator through which large quantities of cooling air are circulated. The condensed water is recirculated to the boiler.

7. Appendix. A2 -- THE TRADITIONAL 1914 STEAM LOCOMOTIVE.

The new technology incorporates new elements influencing the global thermal efficiency. The following list includes practical components and does not claim to be complete nor closed to new advances. It is not ordered. It is not possible to avoid the use of reciprocating engine terminology. In Spanish, Refs (8) and (9) may be consulted.

- (i) surface feed water heaters in which exhaust steam, receiver steam (in compound engines) or cylinder bleed steam (single expansion engines) is the heating medium. Non return valves make the steam pressure in the heater corresponding to release.

This leads to very high feed water temperatures (120 to 150° C in single expansion engines).

- (ii) similarly to the above mentioned case, exhaust steam air heaters. The efficiency increase resulting from both elements is about 25%. Besides, the boiler absorption efficiency (according to the classical definition) increases to some 95% in spite of relatively high flue gas temperatures;
- (iii) economizer in series with (i) and (ii);
- (iv) direct acting, flywheel-less reciprocating feed water pumps. Their steam consumption is very low (= 1% of the feed);
- (v) high efficiency draught ejector: most of the driving energy is taken from that otherwise lost by incomplete expansion;
- (vi) new concepts (cooled cylinder and valve liners, etc.) permitting very high steam temperatures even with conventional ones. Important advances in cylinder tribology (for example "diesel" piston rings) (10);
- (vii) use of the tender as hot water well;
- (viii) fuel heating by means of exhaust steam \approx 1 to 2% improvement;
- (ix) cylinder block insulation and preheating avoiding cold starting losses;
- (x) a new version of compounding beyond the improvements introduced by CHAPELON prior to 1947;
- (xi) an improvement of the general tribology which, it is hoped may lead to a reduction in wear down to one fifth of the traditional figures;
- (xii) general mechanical, operating (adhesion) and ergonomic improvements;
- (xiii) author's advances in boiler feedwater treatments virtually eliminating heavy boiler repairs;
- (xiv) the Gas Producer Combustion System with its high combustion efficiency and its indefinitely continuous steaming;
- (xv) the automatic "one man" operation;
- (xvi) control of environmental pollution: smoke, particulate emissions, gaseous contaminants, perhaps including sulphur emissions;
- (xvii) general cleanliness;
- (xviii) monthly grinding of tyre profile;
- (xix) concerning the theory, it can be mentioned:
 - the great contribution of the heat transfer and fluid dynamics science;
 - a new approach to cylinder wall effects;
 - the possibility of a close engine performance prediction based on applied thermodynamics;
 - new, advanced knowledge in the science of materials; new materials;
 - new, advanced knowledge concerning vehicle-track interaction, etc.
- (xx) the combustion and mechanical firing of fuelwood and forest biomass, now fully utilized;
- (xxi) the "integrated technical package concept";
- (xxii) coal handling in closed containers;

8. Appendix A3 - NON CONDENSING CYCLE FOR A SECOND GENERATION LOCOMOTIVE.

Fig. 6 shows the cycle. It is recalled that the definition of Second Generation refers to a steam power that can be made today, in a commercial fashion with presently available technology. The scheme is presented under a simplified form in view of the purpose of this presentation paper.

The STEPHENSONian boiler (1) produces the saturated steam (2) at an initial pressure of 25 bar. This steam passes through the firetube superheater (3) where its temperature reaches 450°C. After passing through the main steam control valve (4), it works in the high pressure cylinder (5), whose exhaust is reheated to 450° C in a reheater (6). The steam then works in the low pressure cylinder(s) (7); from there, it exhausts to the atmosphere through a high pumping efficiency LEMPOR ejector (8) which draws the flue gases through the firebox and boiler.

The boiler feedwater is carried in a reservoir (9) or tender and is pumped by a direct-acting steam pump (10); its steam cylinder (11) receives the driving steam (12) from the high pressure cylinder exhaust (13). The pump exhaust steam goes to the exhaust steam line (14). The feedwater passes through a first surface heater (15) fed by the exhaust steam (16). This, thanks to a non return valve (17), has a pressure higher than the mean back pressure of the low pressure cylinder, thus leading to a 120 to 135°C feed temperature. The condensate (18) from this heater goes to the forward part of the reservoir (9). After passing through the surface heater (15), the feedwater passes through a second surface heater (19) fed by the steam exhausted from the high pressure cylinder (20). The condensate (21) also goes to the reservoir (9). A non return valve (22) insures that the high pressure cylinder exhaust steam (20) has the maximum pressure, thus leading to a feedwater temperature up to 170°C when the engine works at long cut-offs. After passing through the heaters, it passes through a smokebox economizer (23) where the temperatures reaches some 220°C, thence to the boiler (1).

A continuous blowdown (23) keeps the concentration of dissolved salts and sludge in boiler warmer below 30,000 ppm.

The fuel (24) is fed to the gas producer furnace (25). The air (26) is preheated in a surface heater (27) taking the steam from the exhaust line (14); its temperature reaches 120 to 135°C. The condensate (28) goes to the reservoir (9). A second air-heater (29) is fed by exhaust steam coming from the high pressure cylinder via the line (20). In it, the air temperature reaches some 170°C. The combustion air is divided in primary air (30) and secondary air (31). The primary air is mixed up with some exhaust steam (32), and both make the gasification agent for the fixed fuel bed (33). The combustion gases (34) pass through the firetube bundle and the smokebox economizer (23), and are evacuated to the atmosphere by the ejector (8). The fuel (24) is warmed up at 100°C by means of exhaust steam taken from the line (14) (not shown).

The thermal efficiency measured under the most favorable conditions may reach 17% or perhaps 18%. The total thermal efficiency between the coal mine and the drawbar may be up to 10%, a figure including all kind of losses like internal energy consumption for the mine energy expended in fuel transportation, mechanical losses, lighting up losses, fuel used for keeping the engine under steam during standby, work against the gravity and braking, non optimal driving, energy expenditure of service and repair shops, etc. In terms of energy, this thermal efficiency is the one really interesting, and about which is never spoken about.